

TAHOE-DOUGLAS DISTRICT
P.O. Box 1600
Zephyr Cove, Nevada 89448

Recorded at Request of
On JAN 23 1975 At 10 Min. Past 2 PM
Official Records of Douglas County, Nevada. Fee

Tahoe - Douglas Dist

Patricia J. Stanley, Recorder.
GRANT OF EASEMENT

By *[Signature]*
Deputy

THIS GRANT OF EASEMENT, made this 7 day of March
19 74, between the undersigned "Grantor" and the TAHOE DOUGLAS
DISTRICT, as "GRANTEE":

WITNESSETH, that the Grantor, for valuable consideration, receipt
of which is hereby acknowledged, has granted and conveyed, and by
these presents does grant and confirm into the Grantee, its successors
and assigns, the easements and rights-of-way for the purpose of the
installation and maintenance of sewer utility lines and necessary
appurtenances in the County of Douglas, State of Nevada, and described
in the attached Exhibit "A"; including the right to enter upon the
property described in Exhibit "A" at any time for maintenance, repair
and construction of sewer utility lines -

IN WITNESS WHEREOF, the said Grantor has hereunto set his hand
and seal the day and year first above written.

GRANTOR:

GRANTOR:

James N. Autry

Billie J. Autry

STATE OF California)
) ss.
COUNTY OF Napa)

On this 7 day of March, 19 74, before me, a Notary
Public, in and for the County of Napa, personally appeared

James N. Autry and Billie J. Autry
known to me to be the person(s) whose name(s) is/are subscribed to the
within instrument, and They duly acknowledged to me that They executed
the same.

IN WITNESS WHEREOF, I have hereunto set my hand and affixed my
official seal the day and year in this certificate first above written.

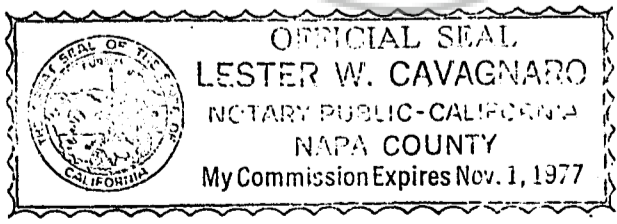

[Signature]
NOTARY PUBLIC

Assessment No. 1318-090-002

77753

BOOK 175 PAGE 1022



ENGINEERS LTD., INC.

CIVIL ENGINEERING -- SURVEYING

P. O. BOX 616
ZEPHYR COVE, NEVADA 89448
PHONE (702) 588-4567

Autry

February 28, 1974

SEWER EASEMENT DESCRIPTION

A parcel of land being a portion of Section 10, T 13 N, R 18 E, M.D.M., Douglas County, Nevada and of Lot 2, Block C, Zephyr Heights No. 4.

An easement for the construction, maintenance and operation of a sewer system is described as follows: The westerly 5' of said Lot 2.

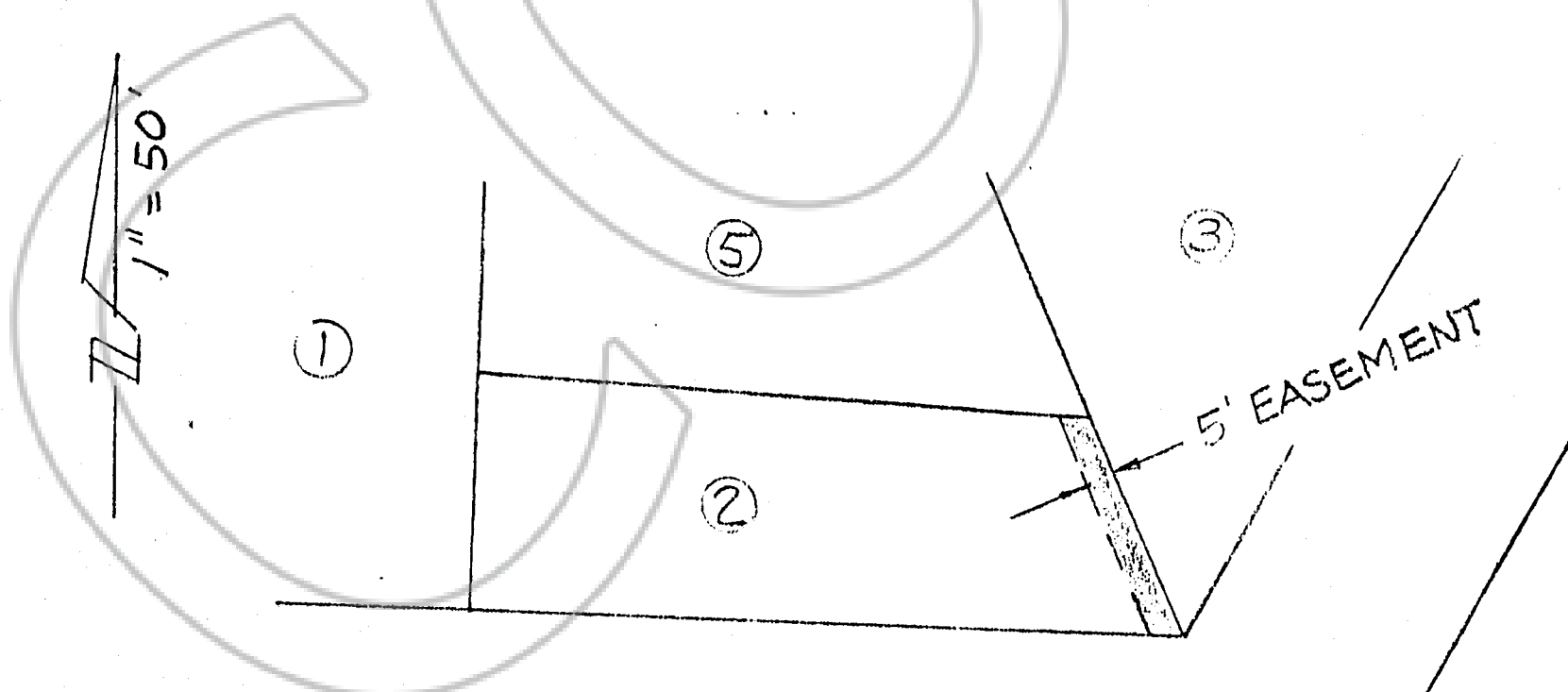

HILLCREST ROAD

77753

BOOK 175 PAGE 1023

1318-090-002

Exhibit "A"

B40