

When recorded, return to:
TAHOE-DOUGLAS DISTRICT
P. O. BOX 1600
ZEPHYR COVE, NEVADA 89448

Recorded at Request of
On JAN 23 1975 At 30 Min. Past 5PM
Official Records of Douglas County, Nevada. Fee 5.00

Tahoe - No. Dist

Patricia J. Stanley, Recorder. By *[Signature]*
Deputy

GRANT OF EASEMENT

THIS GRANT OF EASEMENT, made this 27 day of November,
19 73, between the undersigned "Grantor" and the TAHOE-DOUGLAS
DISTRICT, as "Grantee":

WITNESSETH, that the Grantor, for valuable consideration, receipt
of which is hereby acknowledged, has granted and conveyed, and by
these presents does grant and confirm into the Grantee, its successors
and assigns, the easements and rights-of-way for the purpose of the
installation and maintenance of sewer utility lines and necessary
appurtenances in the County of Douglas, State of Nevada, and described
in the attached Exhibit "A"; including the right to enter upon the
property described in Exhibit "A" at any time for maintenance, repair
and construction of sewer utility lines.

IN WITNESS WHEREOF, the said Grantor has hereunto set his hand
and seal the day and year first above written.

GRANTOR:

GRANTOR:

Walter H. Schuessler

Winifred M. Schuessler

STATE OF California)
) ss.
COUNTY OF Orange)

On this 27th day of November, 19 73 before me, a Notary
Public, in and for the County of Orange, personally appeared
Walter and Winifred Schuessler
known to me to be the person(s) whose name(s) is/are subscribed to the
within instrument, and they duly acknowledged to me that they executed
the same.

IN WITNESS WHEREOF, I have hereunto set my hand and affixed my
official seal the day and year in this certificate first above written.



OFFICIAL SEAL
D. CHRISTENE DALPINO
NOTARY PUBLIC - CALIFORNIA
PRINCIPAL OFFICE IN
LOS ANGELES COUNTY

My Commission Expires May 29, 1977

D. Christene Dalpino
NOTARY PUBLIC **77760**
D. Christene Dalpino

Assessment No. 1318-09E-005

BOOK 175 PAGE 1038



ENGINEERS LTD., INC.

CIVIL ENGINEERING — SURVEYING

P.O. BOX 616
ZEPHYR COVE, NEVADA 89448
PHONE (702) — 588-4567

Walter Schuessler
4114 Magna Carta Rd
Woodland Hills

September 28, 1973

SEWER EASEMENT DESCRIPTION

A parcel of land being a portion of Section 10, T 13 N, R 18 E, M.D.M., and of Lot 5, Block E as shown on that certain map entitled Zephyr Heights No. 5, Official Records of Douglas County, Nevada and being further described as follows:

An easement for constructing, maintaining and operating a sewer system on the easterly 7.5 feet of said Lot 5 of said Zephyr Heights No. 5.

Also a 10 foot wide temporary working easement lying westerly and immediately adjacent to the above described easement.

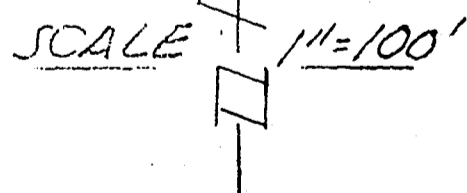
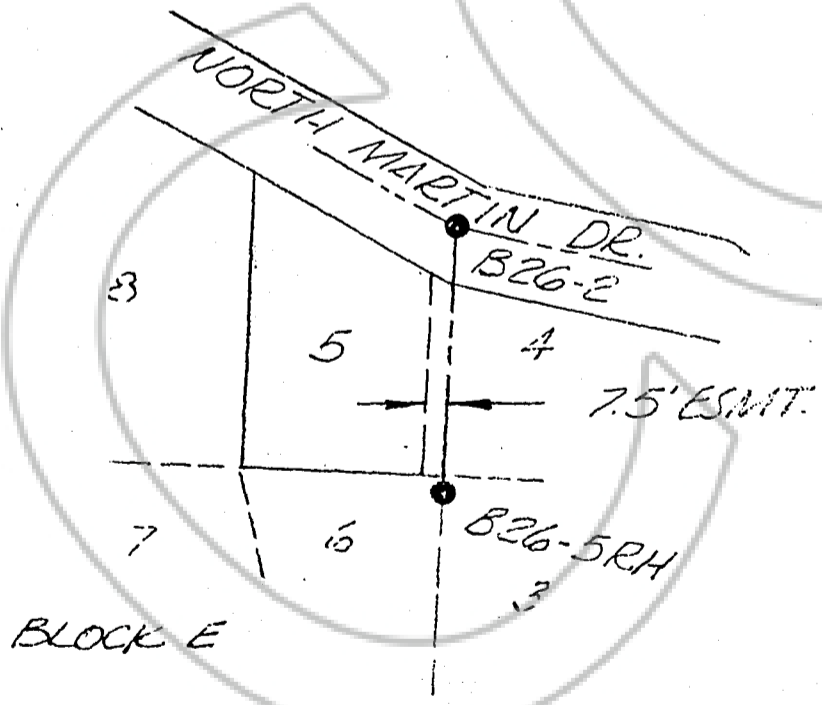

1318-09E-005

Exhibit "A"

77760
BOOK 175 PAGE 1039
B26