

When recorded, return to:  
TAHOE-DOUGLAS DISTRICT  
P. O. BOX 1600  
SEPHYR COVE, NEVADA 89448

GRANT OF EASEMENT

THIS GRANT OF EASEMENT, made this 17<sup>th</sup> day of January, 19 74, between the undersigned "Grantor" and the TAHOE-DOUGLAS DISTRICT, as "Grantee":

WITNESSETH, that the Grantor, for valuable consideration, receipt of which is hereby acknowledged, has granted and conveyed, and by these presents does grant and confirm into the Grantee, its successors and assigns, the easements and rights-of-way for the purpose of the installation and maintenance of sewer utility lines and necessary appurtenances in the County of Douglas, State of Nevada, and described in the attached Exhibit "A"; including the right to enter upon the property described in Exhibit "A" at any time for maintenance, repair and construction of sewer utility lines.

IN WITNESS WHEREOF, the said Grantor has hereunto set his hand and seal the day and year first above written.

GRANTOR:

GRANTOR:

Margaret J. Boyles

STATE OF )  
COUNTY OF ) ss.

On this 17 day of January, 19 74 before me, a Notary Public, in and for the County of Washoe, personally appeared Margaret J. Boyles known to me to be the person(s) whose name(s) is/are subscribed to the within instrument, and She duly acknowledged to me that She executed the same.

IN WITNESS WHEREOF, I have hereunto set my hand and affixed my official seal the day and year in this certificate first above written.

ERIK BEYER  
Notary Public — State of Nevada  
Washoe County  
My Commission Expires Nov. 13, 1977

Erik Beyer  
NOTARY PUBLIC

Assessment No. 1318-09F-003

77763  
BOOK 175 PAGE 1045

TAHOE-DOUGLAS DISTRICT

Post Office Box 1600  
Zephyr Cove, Nevada 89448

A SANITATION DISTRICT AT LAKE TAHOE

Mr. and Mrs. Preston Boyles  
20684 DE LA Guerra  
Woodland Hills, CA 91364

SEWER EASEMENT DESCRIPTION

*Exhibit "A"*

A parcel of land being a portion of Section 10, T 13 N, R 18 E, M.D.M., and of Lot 3, Block F as shown on that certain map entitled Zephyr Heights No. 5, Official Records of Douglas County, Nevada and being further described as follows:

A easement for constructing, maintaining and operating a sewer system on the westerly 7.5 feet of said Lot 3 of said Zephyr Heights No. 5

Also a 10 ft. wide temporary working easement lying easterly and immediately adjacent to the above described easement.

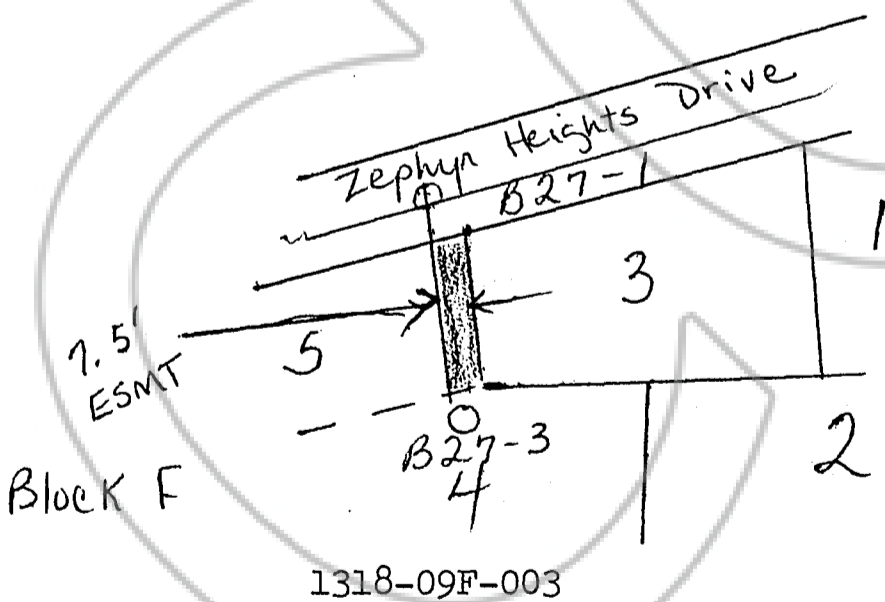

Recorded at Request of *Tahoe - do. Dist Letter*  
On **JAN 23 1975** At *30* Min. Past *9* PM  
Official Records of Douglas County, Nevada. Fee *---*

*+G.E sent  
12/27/72  
4/12/73*

77763

Patricia J. Stanley, Recorder. By *Donald Deed*

BOOK 175 PAGE 1046