

✓ Robert S. Proctor.
64 Linda Vista
Tiburon, CA 94920

Application No. 3566C
Name of Applicant R. S. Proctor
Effective Date 30 October 1981
Expiration Date (If applicable) 31 December 1983

FORM 2830-101 800

(65) 100

DEPARTMENT OF THE ARMY
SACRAMENTO DISTRICT, CORPS OF ENGINEERS
650 CAPITOL MALL
SACRAMENTO, CALIFORNIA 95814

**DEPARTMENT OF THE ARMY
PERMIT**

Referring to written request dated 10 July 1981 for a permit to:

() Perform work in or affecting navigable waters of the United States, upon the recommendation of the Chief of Engineers, pursuant to Section 10 of the Rivers and Harbors Act of March 3, 1899 (33 U.S.C. 403);

~~() Discharge dredged or fill material into waters of the United States upon the issuance of a permit from the Secretary of the Army acting through the Chief of Engineers pursuant to Section 404 of the Federal Water Pollution Control Act (86 Stat. 816, P.L. 92-500);~~

~~() Transport dredged material for the purpose of dumping it into ocean waters upon the issuance of a permit from the Secretary of the Army acting through the Chief of Engineers pursuant to Section 103 of the Marine Protection, Research and Sanctuaries Act of 1972 (86 Stat. 1052; P.L. 92-532);~~

R. S. Proctor, P. O. Box 10145, Zephyr Cove, NV 89440,

is hereby authorized by the Secretary of the Army:
to retain a 4' x 24' extension and construct a 9' extension and a 3' x 15' floating dock,

in Lake Tahoe,

at Douglas County Assessor's Parcel No. 050-02-119,

in accordance with the plans and drawings attached hereto which are incorporated in and made a part of this permit (on drawings: give file number or other definite identification marks.)

"Pier Extension and Floating Dock" revised 27 July 1981,

subject to the following conditions:

i. General Conditions:

a. That all activities identified and authorized herein shall be consistent with the terms and conditions of this permit; and that any activities not specifically identified and authorized herein shall constitute a violation of the terms and conditions of this permit which may result in the modification, suspension or revocation of this permit, in whole or in part, as set forth more specifically in General Conditions j or k hereto, and in the institution of such legal proceedings as the United States Government may consider appropriate, whether or not this permit has been previously modified, suspended or revoked in whole or in part.

67739

Incl 1-1

b. That all activities authorized herein shall, if they involve, during their construction or operation, any discharge of pollutants into waters of the United States or ocean waters, be at all times consistent with applicable water quality standards, effluent limitations and standards of performance, prohibitions, pretreatment standards and management practices established pursuant to the Federal Water Pollution Control Act of 1972 (P.L. 92-500; 86 Stat. 816), the Marine Protection, Research and Sanctuaries Act of 1972 (P.L. 92-532, 86 Stat. 1052), or pursuant to applicable State and local law.

c. That when the activity authorized herein involves a discharge during its construction or operation, of any pollutant (including dredged or fill material), into waters of the United States, the authorized activity shall, if applicable water quality standards are revised or modified during the term of this permit, be modified, if necessary, to conform with such revised or modified water quality standards within 6 months of the effective date of any revision or modification of water quality standards, or as directed by an implementor plan contained in such revised or modified standards, or within such longer period of time as the District Engineer, in consultation with the Regional Administrator of the Environmental Protection Agency, may determine to be reasonable under the circumstances.

d. That the discharge will not destroy a threatened or endangered species as identified under the Endangered Species Act, or endanger the critical habitat of such species.

e. That the permittee agrees to make every reasonable effort to prosecute the construction or operation of the work authorized herein in a manner so as to minimize any adverse impact on fish, wildlife, and natural environmental values.

f. That the permittee agrees that he will prosecute the construction or work authorized herein in a manner so as to minimize any degradation of water quality.

g. That the permittee shall permit the District Engineer or his authorized representative(s) or designee(s) to make periodic inspections at any time deemed necessary in order to assure that the activity being performed under authority of this permit is in accordance with the terms and conditions prescribed herein.

h. That the permittee shall maintain the structure or work authorized herein in good condition and in accordance with the plans and drawings attached hereto.

i. That this permit does not convey any property rights, either in real estate or material, or any exclusive privileges; and that it does not authorize any injury to property or invasion of rights or any infringement of Federal, State, or local laws or regulations nor does it obviate the requirement to obtain State or local assent required by law for the activity authorized herein.

j. That this permit may be summarily suspended, in whole or in part, upon a finding by the District Engineer that immediate suspension of the activity authorized herein would be in the general public interest. Such suspension shall be effective upon receipt by the permittee of a written notice thereof which shall indicate (1) the extent of the suspension, (2) the reasons for this action, and (3) any corrective or preventative measures to be taken by the permittee which are deemed necessary by the District Engineer to abate imminent hazards to the general public interest. The permittee shall take immediate action to comply with the provisions of this notice. Within ten days following receipt of this notice of suspension, the permittee may request a hearing in order to present information relevant to a decision as to whether his permit should be reinstated, modified or revoked. If a hearing is requested, it shall be conducted pursuant to procedures prescribed by the Chief of Engineers. After completion of the hearing, or within a reasonable time after issuance of the suspension notice to the permittee if no hearing is requested, the permit will either be reinstated, modified or revoked.

k. That this permit may be either modified, suspended or revoked in whole or in part if the Secretary of the Army or his authorized representative determines that there has been a violation of any of the terms or conditions of this permit or that such action would otherwise be in the public interest. Any such modification, suspension, or revocation shall become effective 30 days after receipt by the permittee of written notice of such action which shall specify the facts or conduct warranting same unless (1) within the 30-day period the permittee is able to satisfactorily demonstrate that (a) the alleged violation of the terms and the conditions of this permit did not, in fact, occur or (b) the alleged violation was accidental, and the permittee has been operating in compliance with the terms and conditions of the permit and is able to provide satisfactory assurances that future operations shall be in full compliance with the terms and conditions of this permit; or (2) within the aforesaid 30-day period, the permittee requests that a public hearing be held to present oral and written evidence concerning the proposed modification, suspension or revocation. The conduct of this hearing and the procedures for making a final decision either to modify, suspend or revoke this permit in whole or in part shall be pursuant to procedures prescribed by the Chief of Engineers.

l. That in issuing this permit, the Government has relied on the information and data which the permittee has provided in connection with his permit application. If, subsequent to the issuance of this permit, such information and data prove to be false, incomplete or inaccurate, this permit may be modified, suspended or revoked, in whole or in part, and/or the Government may, in addition, institute appropriate legal proceedings.

m. That any modification, suspension, or revocation of this permit shall not be the basis for any claim for damages against the United States.

n. That the permittee shall notify the District Engineer at what time the activity authorized herein will be commenced, as far in advance of the time of commencement as the District Engineer may specify, and of any suspension of work, if for a period of more than one week, resumption of work and its completion.

67739

LIBER 582PAGE 668

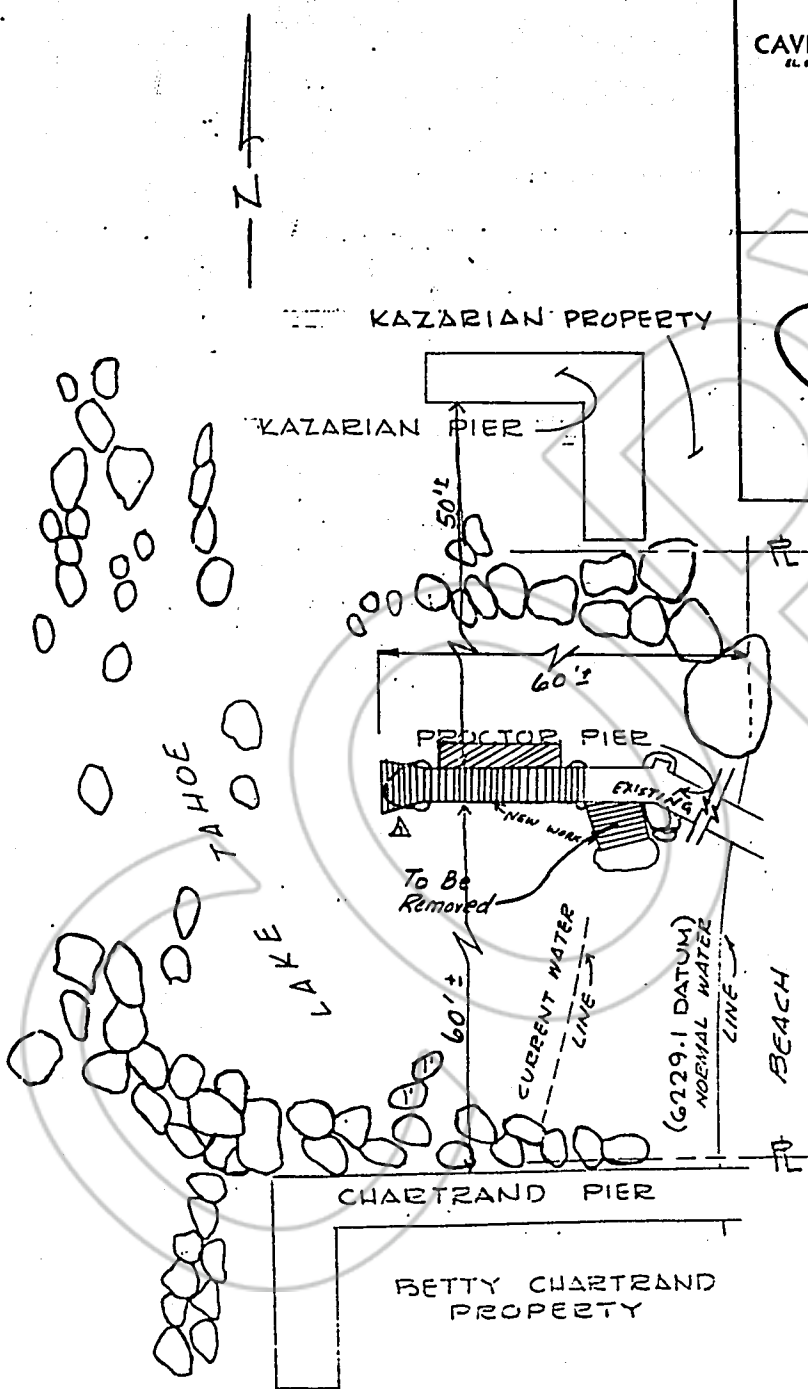
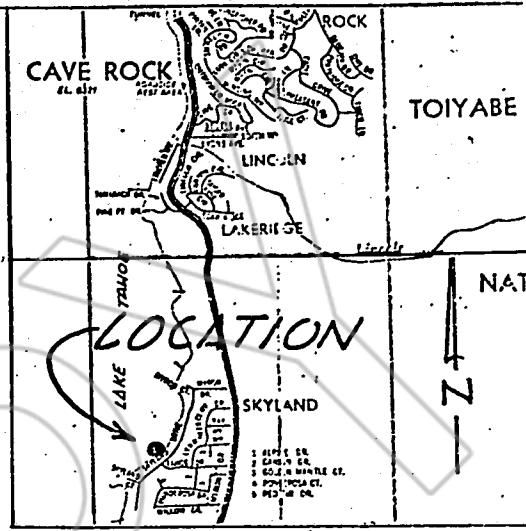

A.P. #
050-02-119

PIER EXTENSION & FLOATING DOCK

LOCATION:
IN LAKE TAHOE
PARCEL NO. 050-02-119
DOUGLAS CO., NV.

APPLICATION BY:
R. S. PROCTOR
1066 SKYLAND DR.
P.O. BOX 10145
ZEPHYR COVE, NV 89448
DATE 1 APRIL 1978
SHEET 1 OF 2

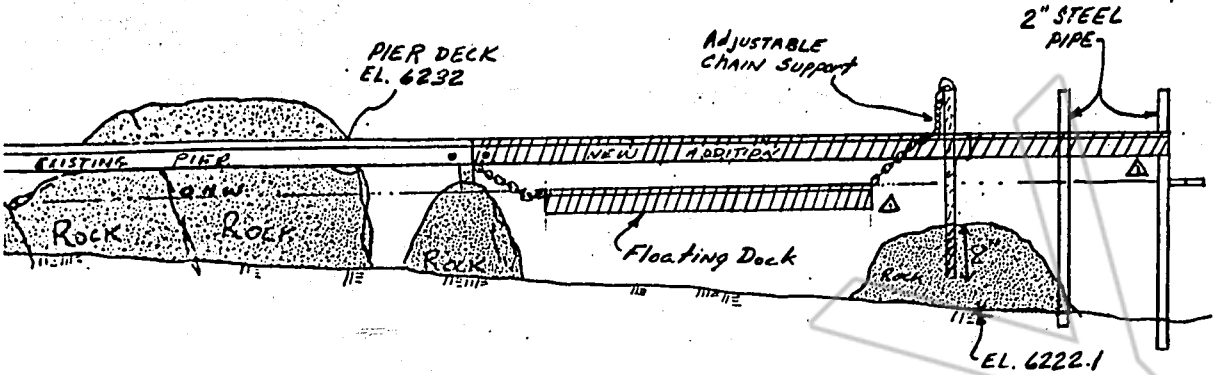

ELEVATION
Scale - 1" = 8'

PLAN
Scale - 1" = 8'

NOTE:
NEW DECK and PIER EXTENSION
CONSTRUCTED OF 2" X 12" and 2" X 6"
DECKING ON 4X8 STRINGERS
ANCHORED TO ROCKS

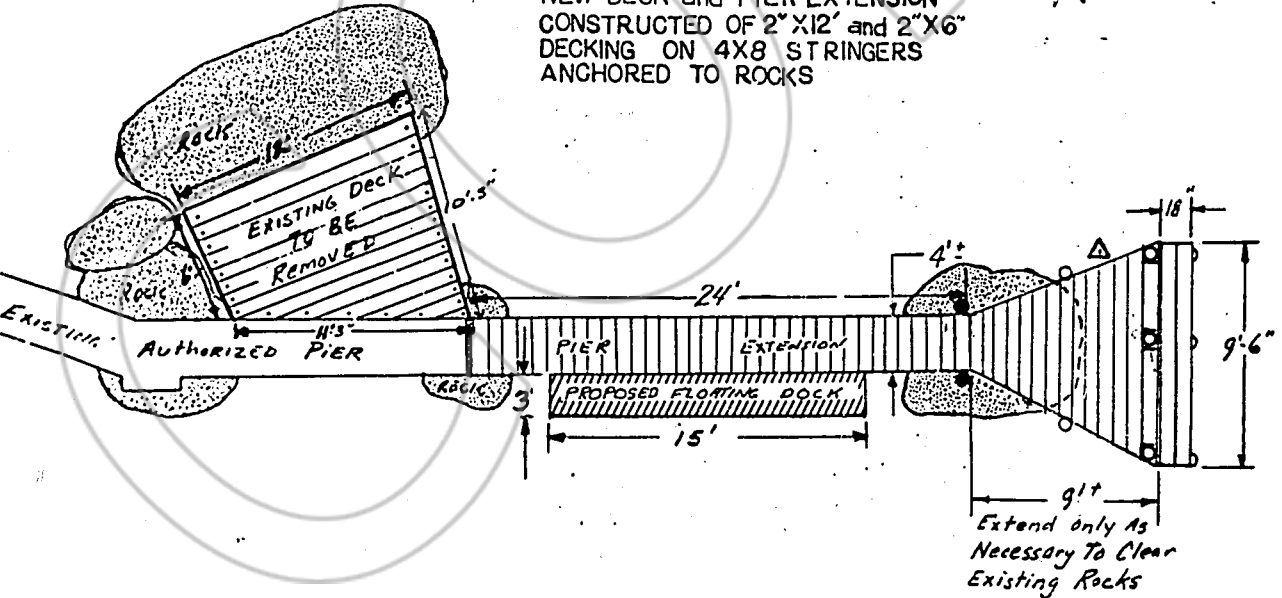

PIER EXTENSION & FLOATING DOCK

Application by: R. S. Proctor
P.O. Box 10145
DATE: 1 April 1976 Zephyr Cove, NV. 89446

67739
LIBER 582 PAGE 670

Revised 27 July 81 Sheet 2 of 2

o. That if the activity authorized herein is not started on or before _____ day of _____ 19____
one year from the date of issuance of this permit unless otherwise specified) and is not completed on or before 31st
day of December, 19 83, (three years from the date of issuance of this permit unless otherwise specified) this permit, if
not previously revoked or specifically extended, shall automatically expire.

p. That this permit does not authorize or approve the construction of particular structures, the authorization or approval of which
may require authorization by the Congress or other agencies of the Federal Government.

q. That if and when the permittee desires to abandon the activity authorized herein, unless such abandonment is part of a transfer
procedure by which the permittee is transferring his interests herein to a third party pursuant to General Condition t hereof, he must
restore the area to a condition satisfactory to the District Engineer.

r. That if the recording of this permit is possible under applicable State or local law, the permittee shall take such action as may be
necessary to record this permit with the Register of Deeds or other appropriate official charged with the responsibility for maintaining
records of title to and interests in real property.

s. That there shall be no unreasonable interference with navigation by the existence or use of the activity authorized herein.

t. That this permit may not be transferred to a third party without prior written notice to the District Engineer, either by the
transferee's written agreement to comply with all terms and conditions of this permit or by the transferee subscribing to this permit in
the space provided below and thereby agreeing to comply with all terms and conditions of this permit. In addition, if the permittee
transfers the interests authorized herein by conveyance of realty, the deed shall reference this permit and the terms and conditions
specified herein and this permit shall be recorded along with the deed with the Register of Deeds or other appropriate official.

II. Special Conditions: (Here list conditions relating specifically to the proposed structure or work authorized by this permit):

(a) That the structure described in this permit and shown on the approved
drawings will not be converted to or used as a recreation room, residence or
temporary dwelling; nor will it be used to moor a recreation room or floating
residence.

The following Special Conditions will be applicable when appropriate:

002 285400 01T

STRUCTURES IN OR AFFECTING NAVIGABLE WATERS OF THE UNITED STATES:

- a. That this permit does not authorize the interference with any existing or proposed Federal project and that the permittee shall not be entitled to compensation for damage or injury to the structures or work authorized herein which may be caused by or result from existing or future operations undertaken by the United States in the public interest.
- b. That no attempt shall be made by the permittee to prevent the full and free use by the public of all navigable waters at or adjacent to the activity authorized by this permit.
- c. That if the display of lights and signals on any structure or work authorized herein is not otherwise provided for by law, such lights and signals as may be prescribed by the United States Coast Guard shall be installed and maintained by and at the expense of the permittee.
- d. That the permittee, upon receipt of a notice of revocation of this permit or upon its expiration before completion of the authorized structure or work, shall, without expense to the United States and in such time and manner as the Secretary of the Army or his authorized representative may direct, restore the waterway to its former conditions. If the permittee fails to comply with the direction of the Secretary of the Army or his authorized representative, the Secretary or his designee may restore the waterway to its former condition, by contract or otherwise, and recover the cost thereof from the permittee.
- e. Structures for Small Boats: That permittee hereby recognizes the possibility that the structure permitted herein may be subject to damage by wave wash from passing vessels. The issuance of this permit does not relieve the permittee from taking all proper steps to insure the integrity of the structure permitted herein and the safety of boats moored thereto from damage by wave wash and the permittee shall not hold the United States liable for any such damage.

MAINTENANCE DREDGING:

- ~~a. That when the work authorized herein includes periodic maintenance dredging, it may be performed under this permit for _____ years from the date of issuance of this permit (ten years unless otherwise indicated):~~
- b. That the permittee will advise the District Engineer in writing at least two weeks before he intends to undertake any maintenance dredging.

DISCHARGES OF DREDGED OR FILL MATERIAL INTO WATERS OF THE UNITED STATES:

- ~~a. That the discharge will be carried out in conformity with the goals and objectives of the EPA Guidelines established pursuant to Section 404(b) of the FWPCA and published in 40 CFR 230:~~
- b. That the discharge will consist of suitable material free from toxic pollutants in other than trace quantities;
- c. That the fill created by the discharge will be properly maintained to prevent erosion and other non-point sources of pollution; and
- d. That the discharge will not occur in a component of the National Wild and Scenic River System or in a component of a State wild and scenic river system.

DUMPING OF DREDGED MATERIAL INTO OCEAN WATERS:

- ~~a. That the dumping will be carried out in conformity with the goals, objectives, and requirements of the EPA criteria established pursuant to Section 102 of the Marine Protection, Research and Sanctuaries Act of 1972, published in 40 CFR 220-228.~~
- b. That the permittee shall place a copy of this permit in a conspicuous place in the vessel to be used for the transportation and/or dumping of the dredged material as authorized herein.

This permit shall become effective on the date of the District Engineer's signature.

21st Subscribed and sworn to before me this
 day of October 1981
 State of California - Principal Office, San Francisco County
 My Commission Expires October 28, 1983
Alice M. Maguire

Permittee hereby accepts and agrees to comply with the terms and conditions of this permit.

x *R. S. Proctor* 10/21/81 x
 PERMITTEE

R. S. PROCTOR
BY AUTHORITY OF THE SECRETARY OF THE ARMY:

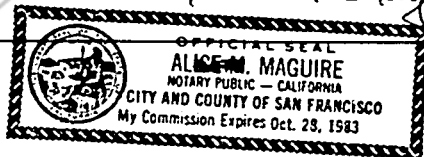

Henry Lee
 HENRY LEE, Lt. Col., CE for
 PAUL F. KAVANAUGH, Colonel, CE

3000081
 DATE

DISTRICT ENGINEER, Sacramento
U.S. ARMY, CORPS OF ENGINEERS

Transferee hereby agrees to comply with the terms and conditions of this permit.

TRANSFEEEE

DATE

STATE OF CALIFORNIA
COUNTY OF SACRAMENTO

On this 30 day of OCTOBER
thousand nine hundred and 81, before me,
MARGARET QUAN, a Notary Public, State of California,
duly commissioned and sworn, personally appeared
LT. COL. HENRY LEE, CE

known to me to be the person whose name
is subscribed to the within instrument and acknowledged to me
that he executed the same.

IN WITNESS WHEREOF I have hereunto set my hand and affixed
my official seal in the County of
SACRAMENTO the day and year in this certificate first
above written.

Margaret Quan
Notary Public, State of California
My commission expires May 6, 1983

This document is only a general form which may be proper for use in simple transactions
and in no way acts, or is intended to act, as a substitute for the advice of an attorney
The publisher does not make any warranty, either express or implied as to the legal
correctness, of any provision or the suitability of these forms in any specific transaction

Cowdery's Form No. 32 — Acknowledgement — General (C. C. Sec. 1190a)



COPIED

REQUESTED BY
Robert Proctor
IN OFFICIAL RECORDS OF
DOUGLAS CO. NEVADA
10-0088
1982 MAY 13 AM 11:56

SUZANNE BEAUDREAU
RECORDER
Betty Henson
Sup
67739
LIBER 582 PAGE 673