

OFFICIAL RECORD

Requested By:

DC/PUBLIC WORKS

Assessor's Parcel Number: N/A

Date: JANUARY 31, 2012

Recording Requested By:

Douglas County - NV
Karen Ellison - Recorder

Page: 1 Of 34 Fee: 0.00

BK-0112 PG- 6072 RPTT: 0.00



Name: EILEEN CHURCH, PUBLIC WORKS
(RR)

Address: _____

City/State/Zip: _____

Real Property Transfer Tax: \$ N/A

CHANGE ORDER NO 15 (#2012 014)
(Title of Document)

CHANGE ORDER

2012.014
 2012 JAN 31 AM 9:46

No. 15 (Final)

PROJECT: No. Douglas County-Carson City Water Line Inter-Tie Project, Phase 1, Section 1

DATE OF ISSUANCE: November 17, 2011 EFFECTIVE DATE: November 17, 2011

County: Douglas County

OWNER's Contract No. PWP-DO-2010-358

CONTRACTOR: Q & D Construction

ENGINEER: Douglas County

You are directed to make the following changes in the Contract Documents.

Description: This Change Order is based on October 13, 2011 negotiations between the contractor and the County, and resolves all claims on the project. See attachments for detailed descriptions of Items No. 1 through No. 6.

Reason for Change Order: See descriptions for Items No. 1 through No. 6.

Attachments: See attachments for Items No. 1 through No. 5.

CHANGE IN CONTRACT PRICE:	CHANGE IN CONTRACT TIMES:
Original Contract Price <u>\$2,823,417.00</u>	Original Contract Times Substantial Completion: <u>March 3, 2011</u> Ready for final payment: <u>March 31, 2011</u> days or dates
Net changes from previous Change Orders No. <u>1</u> to No. <u>14</u> <u>\$76,667.58</u>	Net change from previous Change Orders No. <u>1</u> to No. <u>14</u> . <u>3</u> days
Contract Price prior to this Change Order <u>\$2,900,084.58</u>	Contract Times prior to this Change Order Substantial Completion: <u>March 6, 2011</u> Ready for final payment: <u>April 3, 2011</u> days or dates
Net Increase (decrease) of this Change Order <u>\$61,313.60</u>	Net Increase (decrease) of this Change Order Substantial Completion: <u>180 days</u> Ready for final payment: <u>257 days</u>
Contract Price with all approved Change Orders <u>\$2,961,398.18</u>	Contract Times with all approved Change Orders Substantial Completion: <u>September 30, 2011</u> Ready for final payment: <u>December 16, 2011</u> days or dates

RECOMMENDED:

By: [Signature]
 Engineer (Authorized Signature)

Date: 12-21-11

APPROVED:

By: [Signature]
 Owner (Authorized Signature)

Date: 12-28-11

ACCEPTED:

By: [Signature]
 Contractor (Authorized Signature)

Date: DECEMBER 13, 2011

DOUG ELDER
 PM

RECEIVED

DEC 15 2011

DOUGLAS COUNTY
 PUBLIC WORKS

Attachment to Change Order No. 15

N. Douglas County – Carson City Water Line Inter-Tie Project, Phase 1, Section 1
PWP-DO-2010-358

Item No. 1 **Amount: \$41,031.00**

Description: See below. This is a negotiated amount to resolve Q & D Construction's claim related to the Frontier fiber optic cable.

Reason for Change Order: The existing Frontier fiber optic cable located parallel and adjacent to the water pipe alignment was shown on the contract drawings based on field locates from Frontier during project design. During Construction, it was discovered that the actual location of the fiber optic line was different than shown on the contract drawings. As a result, the direct bury cable ended up inside the contractor's trench, meandering back and forth in an arbitrary fashion for a portion of the project length. This resulted in a decrease in production and, therefore, an increase in costs due to the close proximity of the cable to the work.

Attachments: Letter from Q&D Construction dated June 27, 2011. Letter from Douglas County dated May 31, 2011.

Item No. 2 **Amount: \$16,669.00**

Description: Contractor will proceed with fill station electrical work as outlined in the electrical drawings that were prepared as an attachment to RFI No. 23R1, dated August 22, 2011, in addition to placing required conduits.

Reason for Change Order: The contractor submitted RFI No. 23 to ask for clarification on how to provide power to the fill station card reader and controller system from the existing well house since there was no provision for power at the fill station. The response to the RFI included electrical drawings for this purpose. The contractor claimed that, because there was no electrical plans included in the bid plan set, and because there were no notes directing the contractor to provide power at this location, he did not include electrical in his bid. In addition to electrical work, there were also costs to install electrical conduit from the building to the fill station. Contractor will also use the existing flow meter inside the well building rather than providing and installing a new flow meter.

Attachments: RFI No. 23R1 (with electrical drawings). Revised PCO No. 14 from Q & D dated September 16, 2011.

Item No. 3 **Amount: \$29,300.00**

Description: The contractor demobilized until the wet conditions on the north end of the project improved, and then remobilized and completed the project.

Reason for Change Order: Due to the NV Energy guy wires in conflict with the work, the contractor was not able to complete the northern portion of the water main alignment as the first order of work as originally planned. At the time the contractor was ready to continue work on the northern portion of the water line, the work area was too wet due wetter than normal winter weather to allow construction to proceed as originally planned. Two options were considered to address the site conditions: 1) Over-excavating and building a construction platform to provide access for the contractor's equipment, and 2) demobilizing the contractor and waiting until the conditions improved. The cost to over-excavate was prohibitive, and it was decided demobilize until site conditions improved. When site conditions improved, the contractor remobilized to complete the northern portion of the water line.

Attachments: Letter from Q & D Construction dated November 2, 2011.

Attachment to Change Order No. 15

N. Douglas County – Carson City Water Line Inter-Tie Project, Phase 1, Section 1
PWP-DO-2010-358

Item No. 4 Amount: \$8,000.00

Description: The contractor utilized steel plating along the northern portion of the water line to provide access for equipment while placing water pipe for a total of eight days.

Reason for Change Order: Due to delays from the NV Energy guy wire conflicts with the work the contractor demobilized. When the contractor re-mobilized to complete the water main on the northern segment of the project (see above) to meet the Nevada Division of Environmental Protection compliance date for delivery of water to Indian Hills General Improvement District, the contractor used steel plating in areas that were pumping, rutting and unable to support construction traffic due to wet subsurface conditions.

Attachments: Letter from Q & D Construction November 2, 2011.

Item No. 5 Amount: None

Description: Revise contract dates. Delete paragraph 4.02.B of the Agreement. Delete paragraph 4.02.A and replace with the following:

4.02 Days to Achieve Substantial Completion and Final Payment

A. The Work will be substantially completed on or before September 30, 2011, and completed and ready for final payment in accordance with paragraph 14.07 of the General Conditions on or before December 16, 2011.

Reason for Change Order: Reconcile contract dates due to delays from the NV Energy guy wire conflicts on the northern portion of the project.

Attachments: Letter from D. Barreto dated July 27, 2011.

Item No. 6 Amount: (\$33,686.40)

Description: Reconcile final quantity for Bid Item 14 Wet Trench Construction. Final quantity was 3,368 linear feet. Reduce quantity as follows:

- Original contract bid quantity 5,030 linear feet
- Final constructed quantity 3,638 linear feet
- Reduction in quantity 1,392 linear feet
- Unit price \$24.20/ linear foot
- Reduction in contract price \$33,686.40

Reason for Change Order: Reconcile contract to final quantity.

Attachments: None.

Attachment to Change Order No. 15
N. Douglas County – Carson City Water Line Inter-Tie Project, Phase 1, Section 1
PWP-DO-2010-358

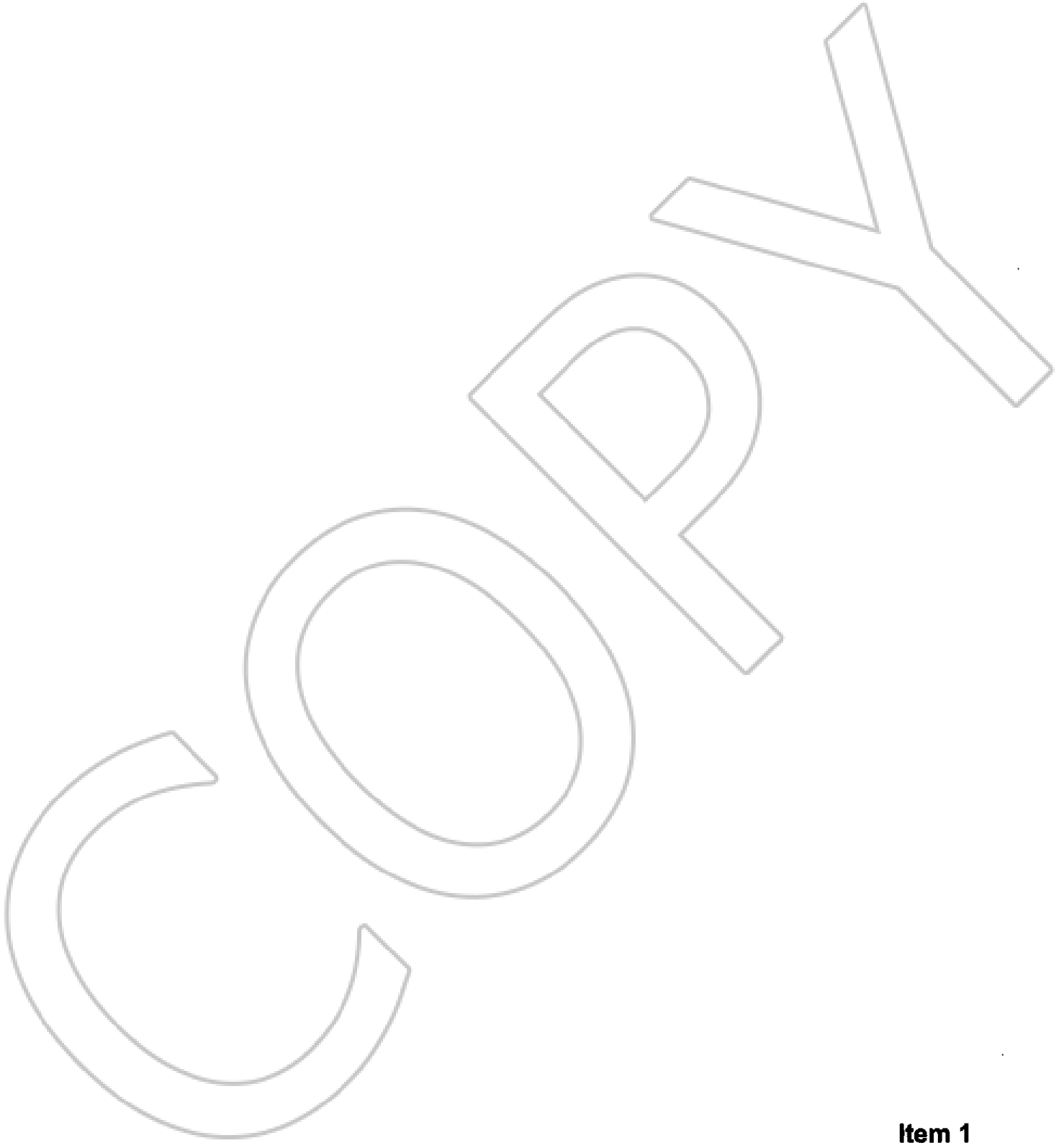

Item 1
Frontier Fiber Optic Cable



Q&D Construction

Main Office
Northern Nevada
P.O. Box 10865
Reno, NV 89510
NCL: 8197A&B
CCL: 427988BA
775.786.2677 ph
775.786.5136 fax

June 27, 2011

Ms. Donette Barreto, P.E.
Project Manager
Douglas County

Project: North Douglas Co.-Carson City Inter-tie Project

RE: Existing Frontier fiber Impact and Time Extension
Waterline Intertie Project: Response to May 31, 2011 Letter
PWP-DO-2010-358

Dear Ms. Barreto,

Q&D is in receipt of your May 31, 2011 letter referenced above. To summarize the letter, Douglas County wishes to bring the contract current and settle all outstanding and potential claims with the Frontier Fiber production, guy wires, potential North area ground water, and time of completion issues by requesting Q&D accept the payment of \$44,274.00 (in lieu of the \$119,119.57 crew delay and the \$29,300.00 remobilization), release from liquidated damages, and the extension of substantial and final completion to August 17, 2011 and August 31, 2011 respectively.

Q&D also wishes to bring the contract current, complete the remaining work in a timely and cost effective manner, as well as receive fair compensation for conditions found different as detailed previously and in part, referenced above.

Q&D requests to meet with all stakeholders and decision makers regarding these issues on or around July 7, 2011.

In review of the offer, it appears Douglas County would have Q&D take some responsibility for the stated issues. In part we assume, due to the claim in paragraph 3 of the 5/31 letter stating "Q&D would not have finished the pipeline in accordance with the terms of the contract or could have met the substantial and final completion dates."

Q&D was not allowed to build the pipeline in accordance with the terms of the contract. Starting the work in the middle of a linear pipeline project and being cut off from roughly 40% of the work area did not allow for multiple crews to work at the same time and eliminated any chance of meeting contractual dates.

**BUILT FOR
A NEW
CENTURY**



Q&D Construction

Main Office
Northern Nevada
P.O. Box 10865
Reno, NV 89510
NCL: 8197A&B
CCL: 427988BA
775.786.2677 ph
775.786.5136 fax

Previous written documentation has established the fact that no aspect of the original schedule had been possible to maintain due to unforeseen contract changes. For example, RFI # 18 pertaining to the need for manways was submitted on November 5, 2010, on January 18, 2011 the change order was approved, and the final field installed manway was received on March 4, 2011. Without the manway, it would not have been safe to continue pipe installation. In summary, the lack of manways, conflicting fiber optic lines, utility conflicts, guy wires, inconsistency and timing of testing, grouting, and welding test procedures are why Q&D could not finish within the allotted time. Q&D has made every attempt to partner with Douglas County and seek reasonable cost effective solutions to these problems.

Q&D Construction will agree to the proposed revised substantial completion date of August 17, 2011 and the Ready for Final Payment Date of August 31, 2011.

While Q&D Construction and Douglas County may not agree with the weather related schedule impact (beyond the norm), higher ground water measurements are proof that conditions at the North end are not as originally found at the beginning of the project. As such, Q&D will not release our right to claim additional compensation for the remaining work if ground water conditions are found different when work resumes.

To date, Q&D Construction has two outstanding claim amounts as referenced in the first paragraph and totaling \$148,419.57. Douglas County's interpretation of eliminating various days for weather or conflicts is not acceptable to Q&D. Q&D's assessment of Douglas County's calculations for the claimed amounts are as follows.

- Q&D Construction will agree to remove December 14, 2010 as it was not a full production day due to rain.
- While December 30, 2010 may have been cold, it is an assumption that production was hindered by the cold and not the fiber. In fact, as shown above, Q&D Construction has demonstrated our willingness to stop work in unsuitable weather. As such, Q&D Construction rejects this assumption as it is not substantiated by the timecards or our actions.
- January 5, 2011 was a tie-in day. However, had Q&D been allowed to work unhindered as originally planned at 400 LF/day, the tie-in for the 3,195 LF section of pipe would have taken place at the end of a normal and full productive day.
- Q&D Construction will agree to a revised production of 242.6 LF/day, based on 3,195 LF of installed pipe for 13 production days. No wet trench was encountered or paid.

**BUILT FOR
A NEW
CENTURY**



Q&D Construction

Main Office
Northern Nevada
P.O. Box 10865
Reno, NV 89510
NCL: 8197A&B
CCL: 427988BA
775.786.2677 ph
775.786.5136 fax

- Douglas County calculated Q&D's actual production from February 1 through February 15 as being 350LF/day as the "County does not believe it is justified to compare Q&D's actual production rate while working around the fiber cable with its estimated production bid production of 400 linear feet per day". While this production rate is accurate for the dates stated, Q&D believes that the window of time is inaccurate as the first 4 days of production (1,640 linear feet) did not have wet trench while the next 10 days did (2,397 linear feet). All of the pipe placed during the fiber conflict had no wet trench and can not be considered a fair comparison. Please review the following table.

Work Period From	To	Production Days (EA)	Pipe Footage Placed (LF)	Production (LF/Day)	Wet Trench (LF)
12/1/2010	2/1/2011	13	3,154	242.62	0
This period reflects the fiber conflict, but with no water conflict.					
2/2/2011	2/8/2011	4	1,640	410.00	0
This period reflects no fiber or wet trench conflict.					
2/9/2011	5/4/2011	10	2,397	239.70	2397
This period reflects 100% wet trench production, with no fiber conflict.					

Comparing the quantity of pipe hindered by the fiber conduit to the various productions.					
	Footage	Production	Days		Total Cost
					\$19853.26/day
QD Calculated	3,154	410	7.69	5.31	\$ 105,367.55
DC Calculated	3,154	350	9.01	3.99	\$ 79,186.15
Actual	3,154	242.62	13	0	

In summary, Q&D will accept \$105,367.55 to settle the fiber optic delay.

As to the remobilization charge, Douglas County requested an estimate of cost as the North end access was ruined by surface and ground water by the time the field installed manway was finally installed. Douglas County decided it was cheaper to remobilize than the alternative of creating access due to wet surface conditions at \$295,000.00. No formal direction was provided by Douglas County to Q&D with regard to continuation of North end work. Q&D made Douglas County aware of our need to demobilize at our May 10, 2011 weekly meeting due to a lack of accessible and productive work. Q&D will require payment of the \$29,300.00 for remobilization.

**BUILT FOR
A NEW
CENTURY**



Q&D Construction

Main Office
Northern Nevada
P.O. Box 10865
Reno, NV 89510
NCL: 8197A&B
CCL: 427988BA
775.786.2677 ph
775.786.5136 fax

Sincerely,

A handwritten signature in black ink, appearing to read 'D. Elder'.

Doug Elder

Cc: file & Lance Semenko, V.P
Mr. Mahmood Azad, County Engineer
Mr. Ron Roman, Senior Civil Engineer
Mr. Carl Ruschmeyer, Director

CO 27

**BUILT FOR
A NEW
CENTURY**



COMMUNITY DEVELOPMENT
1594 Esmeralda Avenue, Minden, Nevada 89423

Planning Division
Engineering Division
Building Division
Regional Transportation
Code Enforcement

Mahmood Azad, P.E.
COUNTY ENGINEER

775-782-9063
FAX: 775-782-6297
website: www.douglascountynv.gov

May 31, 2011

Mr. Doug Elder
Project Manager
Q & D Construction, Inc.
P.O. Box 10865
Reno, NV 89510

RE: Existing Frontier Fiber Impact and Time Extension
Waterline Intertie Project
PWP-DO-2010-358

Dear Doug:

The intent of this letter is to address the outstanding items that were discussed at the May 10, 2011, meeting attended by Q&D, Douglas County, and Manhard Consulting. The specific reason for this letter is to provide in writing Douglas County's position related to extending the contract completion date and to address the claim submitted by Q&D related to the existing fiber optic line impacts. The result, should Q&D agree with the terms outlined in this letter, is to formalize the time extension Q&D has requested and provide additional monetary compensation in a change order.

Q&D has maintained that, because it was unable to perform work on the north end of the Waterline Intertie Project (the "Project") beginning in mid-October, the overall project schedule was adversely impacted and, as a result, Q&D has been unable to complete the work in accordance with the contract documents. While there is some disagreement as to how the initial delay effected the overall schedule, the County does acknowledge that Q&D could not begin construction at the far north end of the project as it had originally planned based on the existence of the NV Energy guy wires. Furthermore, the County also acknowledges that the project schedule has been adversely impacted by the weather.

Estimates have been made as to the overall weather impacts when compared to normal winter weather conditions but a specific number of days has not been agreed to by both parties. It is the County's position, however, that even without working on the north portion of the waterline, and taking into account a significant extension related to weather delays, Q&D would not have finished the pipeline in accordance with the terms of the contract or could have met the substantial and final completion dates. It is Douglas County's intention to resolve these issues in a fair and equitable manner and to provide a time extension to allow the project to be completed in a timeframe that allows future phases of the project to be constructed without an adverse impact to either Q&D or Douglas County.

In your letter dated April 4, 2011, you stated that it would take approximately 50 days to complete the work on the north end of the project. You also stated that "Q&D would like to begin this North end section as soon as the sub-surface and ground conditions are comparable to what they were when we were going to start this project in October 2010." In addition, you reference a \$29,300 charge for demobilization / remobilization based on the schedule that you provided in your April 4, 2011, letter that stated Q&D would resume work at the north end of the project by May 20, 2011.

In an effort to eliminate any further argument related to the delays in the construction schedule and the resulting claims between the parties, the County is prepared to extend the contract completion times as follows:

1. Substantial Completion Date will now be August 17, 2011.
2. Ready for Final Payment Date will now be August 31, 2011.
3. The proposed change order will not include any provision for demobilization / remobilization as suggested in the April 4, 2011 letter.

By accepting these new completion dates, Q&D acknowledges that the extension of the contract is sufficient to cover weather delays, NV Energy guy wire delays, and all other potential delay claims that have occurred prior to the date of this letter (with the exception of the existing fiber optic claim addressed later in this letter). The County acknowledges that Q & D does not give up its right to assert delay-related claims for any work performed after the date of this letter based on currently unknown conditions.

By providing an extension of the contract and relieving Q&D of all liquidated damages accrued by the County through the date of this letter, the County wants to ensure that the work north of the treatment plant will be performed at the original contract price. Specifically, it is understood and agreed that no additional compensation will be provided to Q&D based on differing site conditions specifically related to higher groundwater. The contract and the geotechnical report are clear as it relates to encountering groundwater and that dewatering would be required on this project. The County's granting of a generous extension of time, in excess of what you have requested, is to allow Q&D to access the site and perform the work in the most efficient manner possible thereby allowing Q&D the greatest opportunity to achieve its desired outcome and production. Douglas County can make no guarantees as to the level of groundwater that will be encountered as Q&D completes the work.

In addition to the time extension discussed above, Q&D has prepared a letter, dated April 11, 2011, in which there is a delay claim, based on reduced production as a result of the close proximity of the existing fiber optic line to the trenching operation. The letter provides a comparison between the actual production achieved and an estimated production of 400 lineal feet per day. The letter and associated pricing does not attempt to compare the actual production in other areas of the project but specifically states, "[T]he attached costs are accrued from actual productions of 400 lf daily, not actual daily production achieved in the same area without the existing fiber conflicts." In an effort to determine the true impact of the fiber delays, Douglas County performed the following calculations:

1. Among the fourteen (14) days listed in Q&D's claim and factored into its actual production, four of the days listed had low production due to other issues unrelated to the location of the fiber optic line. We believe these four days should be excluded from your analysis.
 - December 3, 2010 was the day the first unmarked sewer service was hit.

- December 14, 2010 was a bad weather day with rain and snow and the crew left after working only 1-2 hours.
- December 30, 2010 was a very cold day (<20 degrees F.) and progress was slow due to the extremely cold temperatures.
- January 5, 2011 was the day prior to reaching Stephanie Way and the last three pieces of pipe were placed.

Removing these four days from your calculations gives an average of 272 feet of pipe laid per day while working around the fiber cable versus the 228 feet per day you show in Q&D's claim.

2. The County does not believe it is justified to compare Q&D's actual production rate while working around the fiber cable with its estimated bid production of 400 linear feet per day. We looked at your actual production from February 1 through February 15, after the fiber cable had been moved out of the way, and Q&D's actual production averaged 350 feet per day during that time.
3. We have compared the rate of 350 ft/day to 272 ft/day as the basis for calculating your cost impact due to this utility conflict.

If the 2,720 lf of pipe had been installed at 350 lf/day, then the work would have taken 7.8 days to complete instead of the 10 days that were actually needed. As a result, the overall impact due to the proximity of the fiber line is 2.2 days. If we accept your estimated daily crew costs of \$17,275 per day, plus 15% overhead and profit, and multiple it by 2.2 days, then the total monetary impact due to the fiber optic cable would be \$44,274.00.

As a result of this analysis, Douglas County is prepared to offer Q&D an additional \$44,274 as compensation for any delays in production experienced by Q&D due to the proximity of the fiber optic cable as described in your April 11, 2011, letter.

In order to bring the contract current, as it relates to the construction schedule and to address the fiber optic line impact claim, Douglas County will extend the substantial completion date to August 17, 2011, the final completion date to August 31, 2011, and execute a change order in the amount of \$44,274.00 to resolve all disputed delay claims between the parties as of the date of this letter. The County acknowledges there are other outstanding claims not related to the issues addressed in this letter. If this is acceptable to you, then please let us know as soon as possible so that these changes can be prepared for approval.

Once I hear from you, I will have an agreement prepared and the change orders can be resolved. Meanwhile, please contact me if you have any questions.

Sincerely,



Donette Barreto, P.E.
Project Manager

Attachment to Change Order No. 15
N. Douglas County – Carson City Water Line Inter-Tie Project, Phase 1, Section 1
PWP-DO-2010-358

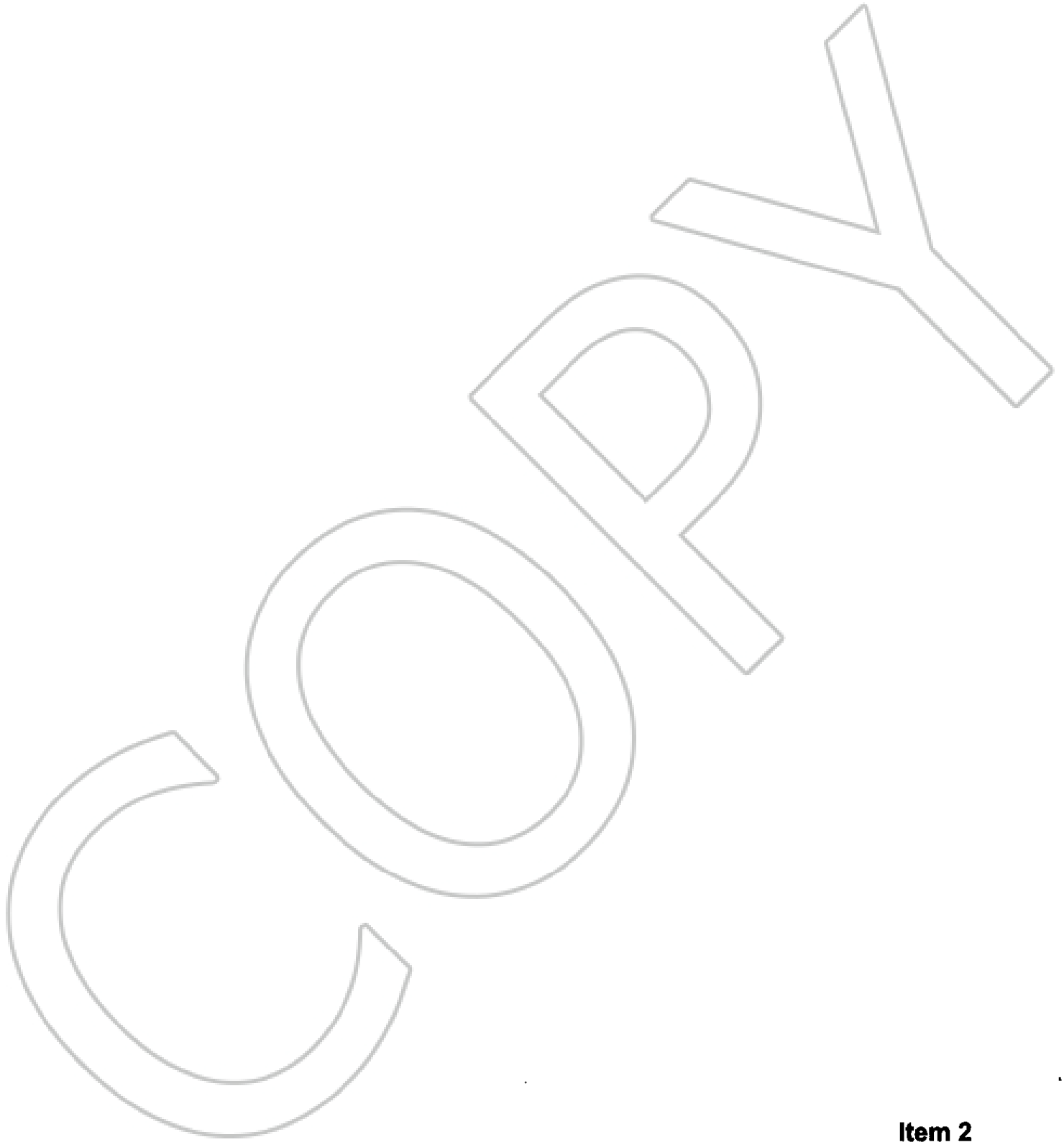

Item 2
Fill Station



Q&D CONSTRUCTION INC.
BUILDING • GENERAL ENGINEERING • DEVELOPMENT • MILLWORK

Request for Information

Project Name: Douglas-Carson Inter-tie	Project #: 12227
Date of Request: 1-Jun-11	Date Required: 15-Jun-11
Requested By: Doug Elder	Requested Of: Douglas County
Subject: Electrical Information - Fill Station	Cc: Mahmood Azad

Reference: RFI #23-R-1

Question or Problem: Q&D would like to request detailed information on the Fill Station Electrical supply from the existing well house. Q&D would like to have drawing showing the existing equipment, connections, wiring, voltage, and circuiting routing. The attached email is insufficient for construction.

Suggestion:

Response:

Please see attached electrical drawings and forward a proposed cost for this work.

Response By: <i>D. Brando</i>	Date: 8/5/11
-------------------------------	--------------



Q & D CONSTRUCTION, INC.

DEVELOPMENT | BUILDING | GENERAL ENGINEERING | TENANT IMPROVEMENTS | MILLWORK

September 16, 2011

1594 Esmeralda Ave.
P.O. Box 218
Minden, NV 89423

RE: CO #14 - Revised - Electrical Power to Fill Station Card Reader

Dear Ms. Donette Barretto,

Please see below for the cost impact to Q&D, and the attached for back-up information. The Previous Work line item is for the work already complete by Q&D, that was approved in the past.

Labor:	\$	788.86
Equipment:	\$	523.58
Materials:	\$	103.50
Subs:	\$	13,353.35
Previous Work	\$	1,900.00
Total:	\$	<u>16,669.29</u>

Thank You for allowing Q & D Construction to quote you on the above referenced project.

Q & D Constructions exclusions are as follows:

- Engineering Material Compaction Testing and/or inspection fees
- Demo, Discharge, Grading Fees or Permits, if required
- Over-excavation of any material
- Survey (Manhard - Subcontractor)
- Dust Control for Q & D work only
- Anything not specifically mentioned on the following quote is excluded

Sincerely,

Doug Elder

TEL: 775-786-2677
FAX: 775-786-5136

P.O. BOX 10865, RENO, NV 89510
1050 S. 21ST STREET, SPARKS, NV 89431

NCL: 8197A&B
CCL: 427988BA

No. Douglas Co.-Carson City Inter-tie
 JOB # 12227
EXTRA WORK REPORT



Q&D CONSTRUCTION INC.
 BUILDING • GENERAL ENGINEERING • DEVELOPMENT • MILLWORK

DATE PERFORMED: _____ **DESCRIPTION:** Electrical Power to Fill Station not depicted on plans
DATE OF REPORT: September 16, 2011 **REVISED** _____

TOTAL OF EQUIPMENT:	\$ 523.58	TOTAL THIS REPORT
TOTAL OF LABOR:	\$ 788.86	
TOTAL OF SUBCONTRACTORS:	\$ 12,717.48	
TOTAL OF MATERIAL AND/OR WORK:	\$ 103.50	

\$ 14,133.42

HRLY RATE + 15%	EQUIPMENT	HOURS	TOTALS
\$ 94.32	966G II Loaders		\$ -
\$ 176.24	EV460BLC Excavator		\$ -
\$ 133.03	EC360B LC Excavator		\$ -
\$ 110.33	EC290B LC Excavator		\$ -
\$ 42.49	420D Backhoe	4.0	\$ 169.96
\$ 126.76	14H Blade		\$ -
\$ 138.99	D7 Dozer		\$ -
\$ 47.92	Forklift		\$ -
\$ 4.79	3" Pump		\$ -
\$ 44.93	Compactor - walk along		\$ -
\$ 37.46	Hand Compactor - wacker	4.0	\$ 149.83
\$ 17.70	Foreman Pickup		\$ -
\$ 47.12	10 Wheelers - Trucks		\$ -
\$ 61.19	Water Truck	1.0	\$ 61.19
\$ 71.30	Double Transfer Trucks	2.0	\$ 142.61
\$ 35.41	Flat Bed Truck		\$ -
\$ 115.00	Boom Truck		\$ -
\$ 5.92	Air Compressor		\$ -
\$ 80.50	Welding Truck		\$ -
\$ 168.75	Welder w/ truck/equipt		\$ -
	Non-certified		\$ -

HRLY RATE + 15%	LABOR RATES	HOURS	TOTALS
\$94.30	Superintendent	1.0	\$ 94.30
\$141.45	Superintendent OT		\$ -
\$69.44	Foreman		\$ -
\$98.16	Foreman OT		\$ -
\$52.24	Carpenter		\$ -
\$69.90	Carpenter OT		\$ -
\$64.95	Equipment Operator	4.0	\$ 259.80
\$86.57	Operator OT		\$ -
\$42.96	Laborer	6.0	\$ 257.76
\$56.37	Laborer OT		\$ -
\$38.08	Flagger		\$ -
\$50.79	Flagger OT		\$ -
\$48.25	Truck Driver	2.0	\$ 96.50
\$48.77	Truck Driver OT		\$ -
\$61.44	Welder		\$ -
\$81.86	Welder OT		\$ -
\$80.50	Project Manager	1.0	\$ 80.50
\$67.50	Project Engineer		\$ -
			\$ -

MATERIALS + 15%	INVOICED AMOUNT	+ 15%	TOTALS
AC Patching	\$ 65.00	\$ 9.75	\$ 74.75
Backfill Sand	\$ 25.00	\$ 3.75	\$ 28.75
			\$ -
			\$ -
			\$ -
			\$ -
			\$ -

HRLY RATE + 6%	SUBCONTRACTORS	HOURS	TOTALS
\$ 12,717.48	Titan Electrical	1.0	\$ 12,717.48
			\$ -
			\$ -
			\$ -
			\$ -
			\$ -

FOREMAN SIGNATURE

OWNERS REPRESENTATIVE

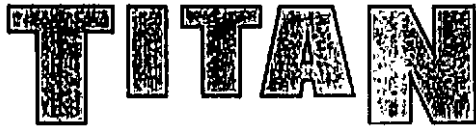

ELECTRICAL
CONTRACTING

Change Order 01R JOB #1100

To: Doug Elder Job Name: Water Tie Project Phase 1

Company: Q&D Construction Change Re: Added Power

Address: Date: 8.27.2011

Phone: 7757862677 Fax:

Work Scope:
Install electrical components provided by LA Perks for a water-fill station, as described in the REVISED Sheets E 1 thru E3

- Exclusions:**
- Fuel Master parts, programing, or start-up.
 - Trench or back
 - Permits, Fees or Bonds

Price as described in attached break down is \$12,717

Titan Electrical Contracting will only proceed with this work upon return of this proposal signed by a person authorized to approve work and payment at this location.

Approved By: _____ Date: _____



8/27/2011 2:37:24 PM

Page 1

Douglas County Water
Totals (Summary) - Bid Summary: Default

Material	
Non-Quoted	\$6,201.72
Quotes	0.00
Sales Tax (7.50%)	465.13
Total Material	\$6,666.85
Labor	
Direct (75.30 hours @ \$85.00)	\$4,894.50
Non-Productive Labor	0.00
Total Labor	\$4,894.50
Direct Job Expenses	\$0.00
Tools and Miscellaneous Materials	0.00
Subcontracts	0.00
Job Subtotal (Prime Cost)	\$11,561.35
Overhead (0.00%)	0.00
Profit (10.00%)	1,156.13
Job Total	\$12,717.48
 Actual Bid Price	 \$12,717.48
 Material to Direct Labor ratio: 0.58	
Prime Cost per square foot	\$0.00
Job Total per square foot	\$0.00
Actual Bid Price per square foot	\$0.00
Labor cost per square foot	\$0.00

COOPER

8/27/2011 2:36:14 PM

Page 1

**Douglas County Water
Extension By Phase**

Item #	Description	Quantity	Price U	Ext Price	Labor Hr U	Ext Lab Hr
-- 01 Raceway, Fittings & Boxes --						
1002	1" EMT	120	70.92 C	85.10	2.50 C	3.00
1177	1" PVC Coated Rigid Steel	480	517.59 C	2,484.43	4.50 C	21.60
1339	1" EMT Elbow	6	264.06 C	15.84	0.15 E	0.90
1349	1" GRC Elbow	15	1,892.25 C	283.84	0.36 E	5.40
1428	1" Set Screw Die Cast Conn	6	65.51 C	3.93	0.15 E	0.90
1578	1" Compression Steel Cplg	18	348.95 C	62.81	0.16 E	2.88
1588	1" Locknut	8	38.96 C	3.12	0.02 E	0.16
1600	1" Plastic Bushing	4	26.43 C	1.06	0.02 E	0.08
1664	1" Myers Hub	4	6.52 E	26.08	0.11 E	0.44
1779	1" X Close Nipple	4	357.14 C	14.29	0.08 E	0.32
2022	1" PVC Coated Rigid Coupling	39	371.50 C	144.89	0.08 E	3.12
2280	1" 1-Hole Strap	15	59.18 C	8.88	2.29 C	0.34
2623	2G FSC Box-1" Hubs	3	25.97 E	77.91	0.37 E	1.11
-- 01 Raceway, Fittings & Boxes Total --				3,212.18		40.25
-- 02 Wire & Cable --						
2790	#12 THHN CU Stranded Wire	672	233.91 M	157.19	5.50 M	3.70
-- 02 Wire & Cable Total --				157.19		3.70
-- 03 Distribution --						
3960	20A 1P 120/240V Bolt-On Circuit Breaker	1	18.43 E	18.43	0.20 E	0.20
3969	20A 2P 120/240V Bolt-On Circuit Breaker	1	41.89 E	41.89	0.25 E	0.25
3985	40A 3P 120/240V Bolt-On Circuit Breaker	1	137.03 E	137.03	0.50 E	0.50
-- 03 Distribution Total --				197.35		0.95
-- 07 Misc --						
T0001	200A Trip Unit	1	425.00 E	425.00	3.00 E	3.00
T0002	N-9 Box with extension	1	100.00 E	100.00	2.00 E	2.00
T0003	Belden 8790	1,000	450.00 M	450.00	4.00 M	4.00
T0004	Install and Connect Truck-Fill Pedestal	1	50.00 E	50.00	6.00 E	6.00
T0005	Install and Connect Truck Fill Control Panel	1	75.00 E	75.00	8.00 E	8.00
T0006	RS232 Custom Cable with DB9 Ends	200	1.00 E	200.00	12.00 M	2.40
T0007	Eaton TVSS	1	1,300.00 E	1,300.00	4.00 E	4.00
T0008	USB to 9DB adpt	1	35.00 E	35.00	1.00 E	1.00
-- 07 Misc Total --				2,835.00		30.40
Job Total				6,201.72		75.30

* Target, Labor column 2

PANELBOARD SCHEDULE

LOCATION: WELL HOUSE
3-PHASE, 4-WIRE

NO.	LOAD KVA			DESCRIPTION	BREAKER			LOAD KVA	WIRING SURFACE BUS AMPERE: 255A	
	A-B	B-C	C-A		AMP	P	A-B			B-C
1	1.00	2.50	2.50	3	30	30	30	1.20	1.20	1.20
2	2.50	1.00	1.00	3	30	30	30	1.20	1.50	1.20
3	1.00	1.00	1.00	3	30	30	30	0.30	0.30	0.30
4	1.00	1.00	1.00	3	30	30	30	1.20	0.30	0.30
5	1.00	0.00	0.00	3	30	30	30	0.00	0.00	0.00
6	1.00	0.00	0.00	3	30	30	30	0.00	0.00	0.00
7	1.00	0.00	0.00	3	30	30	30	0.00	0.00	0.00
8	1.00	0.00	0.00	3	30	30	30	0.00	0.00	0.00
9	1.00	0.00	0.00	3	30	30	30	0.00	0.00	0.00
10	1.00	0.00	0.00	3	30	30	30	0.00	0.00	0.00
11	1.00	0.00	0.00	3	30	30	30	0.00	0.00	0.00
12	1.00	0.00	0.00	3	30	30	30	0.00	0.00	0.00
13	1.00	0.00	0.00	3	30	30	30	0.00	0.00	0.00
14	1.00	0.00	0.00	3	30	30	30	0.00	0.00	0.00
15	1.00	0.00	0.00	3	30	30	30	0.00	0.00	0.00
16	1.00	0.00	0.00	3	30	30	30	0.00	0.00	0.00
17	1.00	0.00	0.00	3	30	30	30	0.00	0.00	0.00
18	1.00	0.00	0.00	3	30	30	30	0.00	0.00	0.00
19	1.00	0.00	0.00	3	30	30	30	0.00	0.00	0.00
20	1.00	0.00	0.00	3	30	30	30	0.00	0.00	0.00
21	1.00	0.00	0.00	3	30	30	30	0.00	0.00	0.00
22	1.00	0.00	0.00	3	30	30	30	0.00	0.00	0.00
23	1.00	0.00	0.00	3	30	30	30	0.00	0.00	0.00
24	1.00	0.00	0.00	3	30	30	30	0.00	0.00	0.00
25	1.00	0.00	0.00	3	30	30	30	0.00	0.00	0.00
26	1.00	0.00	0.00	3	30	30	30	0.00	0.00	0.00
27	1.00	0.00	0.00	3	30	30	30	0.00	0.00	0.00
28	1.00	0.00	0.00	3	30	30	30	0.00	0.00	0.00
29	1.00	0.00	0.00	3	30	30	30	0.00	0.00	0.00
30	1.00	0.00	0.00	3	30	30	30	0.00	0.00	0.00
31	1.00	0.00	0.00	3	30	30	30	0.00	0.00	0.00
32	1.00	0.00	0.00	3	30	30	30	0.00	0.00	0.00
33	1.00	0.00	0.00	3	30	30	30	0.00	0.00	0.00
34	1.00	0.00	0.00	3	30	30	30	0.00	0.00	0.00
35	1.00	0.00	0.00	3	30	30	30	0.00	0.00	0.00
36	1.00	0.00	0.00	3	30	30	30	0.00	0.00	0.00
37	1.00	0.00	0.00	3	30	30	30	0.00	0.00	0.00
38	1.00	0.00	0.00	3	30	30	30	0.00	0.00	0.00
39	1.00	0.00	0.00	3	30	30	30	0.00	0.00	0.00
40	1.00	0.00	0.00	3	30	30	30	0.00	0.00	0.00
41	1.00	0.00	0.00	3	30	30	30	0.00	0.00	0.00
42	1.00	0.00	0.00	3	30	30	30	0.00	0.00	0.00
43	1.00	0.00	0.00	3	30	30	30	0.00	0.00	0.00
44	1.00	0.00	0.00	3	30	30	30	0.00	0.00	0.00

PANEL 'LA' SCHEDULE

SCALE: NOT TO SCALE

NO.	DESCRIPTION	LOAD KVA
1	3	30
2	3	30
3	3	30
4	3	30
5	3	30
6	3	30
7	3	30
8	3	30
9	3	30
10	3	30
11	3	30
12	3	30
13	3	30
14	3	30
15	3	30
16	3	30
17	3	30
18	3	30
19	3	30
20	3	30
21	3	30
22	3	30
23	3	30
24	3	30
25	3	30
26	3	30
27	3	30
28	3	30
29	3	30
30	3	30
31	3	30
32	3	30
33	3	30
34	3	30
35	3	30
36	3	30
37	3	30
38	3	30
39	3	30
40	3	30
41	3	30
42	3	30
43	3	30
44	3	30

GENERAL ELECTRICAL REQUIREMENTS:

1. THIS CONTRACTOR SHALL GUARANTEE TO THE OWNER THE WORKMANSHIP OF HIS ELECTRICAL SYSTEMS AND MATERIALS FOR A PERIOD OF ONE (1) YEAR FROM DATE OF FINAL ACCEPTANCE.

2. CONTRACTOR SHALL PERFORM 300VDC INSULATION MEGGER TESTING ON ALL NEWLY INSTALLED ELECTRICAL CABLES, AND SHALL OBTAIN CERTIFICATE OF RESISTANCE OF SOMEWHAT-BERKSHIRE.

3. WAGER CONTRACTOR ENERGIIZE ENCLOSURES OR ELECTRICAL CABINETS, CONTRACTOR TO PROVIDE WATER TIGHT HOURS. LOCKS MUST BE NOT PERMITTED FOR THE ELECTRICAL WORK.

4. SUBMIT SIX (6) COPIES OF SHOP DRAWINGS AND/OR ELECTRICAL EQUIPMENT FOR APPROVAL WITHIN THIRTY (30) DAYS AFTER AWARD OF CONTRACT. THE CONTRACTOR SHALL PROVIDE ALL SHOP DRAWINGS AND MATERIALS ACCEPTABLE TO THE CONTRACTOR'S ACCEPTANCE. SHOP DRAWINGS SHALL BE KEPT IN THE PROJECT OFFICE UNTIL THE PROJECT IS COMPLETE. ANY CHANGES TO THE SHOP DRAWINGS SHALL BE KEPT IN THE PROJECT OFFICE UNTIL THE PROJECT IS COMPLETE.

5. ALL EXPOSED CONDUIT TO BE GALVANIZED RIGID STEEL TYPE. ALL BURIED CONDUIT WITHIN 6" OF STEEL SHALL BE GALVANIZED RIGID STEEL TYPE. ALL PVC-COATED CONDUIT SYSTEMS TO BE COMPLETE WITH PVC-COATED WBS, UNBUNG, FITTINGS, ETC. PVC-COATED WBS, UNBUNG, FITTINGS, ETC. TO BE 1/2" MICRONS PER FOR PERMA-COTE (MAD).

6. ALL CONCRETE WORK TO BE PER CIVIL DRAWINGS AND DIAGRAMS.

7. ALL STEEL WITH MATCHING COVERS TO BE 'F5' CAST.

8. ALL CONCRETE WORK TO BE PER CIVIL DRAWINGS AND DIAGRAMS.

9. PROVIDE AND INSTALL A 30-A 3-POLE 3-4-WIRE TRUCK-FILL BREAKER TO THE TRUCK-FILL PANEL.

10. VALUING AND CONNECT TRVS ADJACENT TO EXISTING PANEL.

11. PROVIDE AND INSTALL 40A 3-POLE CIRCUIT BREAKER FOR NEW TRVS SUBCIRCUIT.

12. PROVIDE AND INSTALL A 30-A 3-POLE 3-4-WIRE TRUCK-FILL BREAKER TO THE TRUCK-FILL PANEL.

13. VALUING AND CONNECT TRVS ADJACENT TO EXISTING PANEL.

14. PROVIDE AND INSTALL 40A 3-POLE CIRCUIT BREAKER FOR NEW TRVS SUBCIRCUIT.

15. PROVIDE AND INSTALL A 30-A 3-POLE 3-4-WIRE TRUCK-FILL BREAKER TO THE TRUCK-FILL PANEL.

16. VALUING AND CONNECT TRVS ADJACENT TO EXISTING PANEL.

17. PROVIDE AND INSTALL 40A 3-POLE CIRCUIT BREAKER FOR NEW TRVS SUBCIRCUIT.

18. PROVIDE AND INSTALL A 30-A 3-POLE 3-4-WIRE TRUCK-FILL BREAKER TO THE TRUCK-FILL PANEL.

19. VALUING AND CONNECT TRVS ADJACENT TO EXISTING PANEL.

20. PROVIDE AND INSTALL 40A 3-POLE CIRCUIT BREAKER FOR NEW TRVS SUBCIRCUIT.

21. PROVIDE AND INSTALL A 30-A 3-POLE 3-4-WIRE TRUCK-FILL BREAKER TO THE TRUCK-FILL PANEL.

22. VALUING AND CONNECT TRVS ADJACENT TO EXISTING PANEL.

23. PROVIDE AND INSTALL 40A 3-POLE CIRCUIT BREAKER FOR NEW TRVS SUBCIRCUIT.

24. PROVIDE AND INSTALL A 30-A 3-POLE 3-4-WIRE TRUCK-FILL BREAKER TO THE TRUCK-FILL PANEL.

25. VALUING AND CONNECT TRVS ADJACENT TO EXISTING PANEL.

26. PROVIDE AND INSTALL 40A 3-POLE CIRCUIT BREAKER FOR NEW TRVS SUBCIRCUIT.

27. PROVIDE AND INSTALL A 30-A 3-POLE 3-4-WIRE TRUCK-FILL BREAKER TO THE TRUCK-FILL PANEL.

28. VALUING AND CONNECT TRVS ADJACENT TO EXISTING PANEL.

29. PROVIDE AND INSTALL 40A 3-POLE CIRCUIT BREAKER FOR NEW TRVS SUBCIRCUIT.

30. PROVIDE AND INSTALL A 30-A 3-POLE 3-4-WIRE TRUCK-FILL BREAKER TO THE TRUCK-FILL PANEL.

31. VALUING AND CONNECT TRVS ADJACENT TO EXISTING PANEL.

32. PROVIDE AND INSTALL 40A 3-POLE CIRCUIT BREAKER FOR NEW TRVS SUBCIRCUIT.

33. PROVIDE AND INSTALL A 30-A 3-POLE 3-4-WIRE TRUCK-FILL BREAKER TO THE TRUCK-FILL PANEL.

34. VALUING AND CONNECT TRVS ADJACENT TO EXISTING PANEL.

35. PROVIDE AND INSTALL 40A 3-POLE CIRCUIT BREAKER FOR NEW TRVS SUBCIRCUIT.

36. PROVIDE AND INSTALL A 30-A 3-POLE 3-4-WIRE TRUCK-FILL BREAKER TO THE TRUCK-FILL PANEL.

37. VALUING AND CONNECT TRVS ADJACENT TO EXISTING PANEL.

38. PROVIDE AND INSTALL 40A 3-POLE CIRCUIT BREAKER FOR NEW TRVS SUBCIRCUIT.

39. PROVIDE AND INSTALL A 30-A 3-POLE 3-4-WIRE TRUCK-FILL BREAKER TO THE TRUCK-FILL PANEL.

40. VALUING AND CONNECT TRVS ADJACENT TO EXISTING PANEL.

41. PROVIDE AND INSTALL 40A 3-POLE CIRCUIT BREAKER FOR NEW TRVS SUBCIRCUIT.

42. PROVIDE AND INSTALL A 30-A 3-POLE 3-4-WIRE TRUCK-FILL BREAKER TO THE TRUCK-FILL PANEL.

43. VALUING AND CONNECT TRVS ADJACENT TO EXISTING PANEL.

44. PROVIDE AND INSTALL 40A 3-POLE CIRCUIT BREAKER FOR NEW TRVS SUBCIRCUIT.

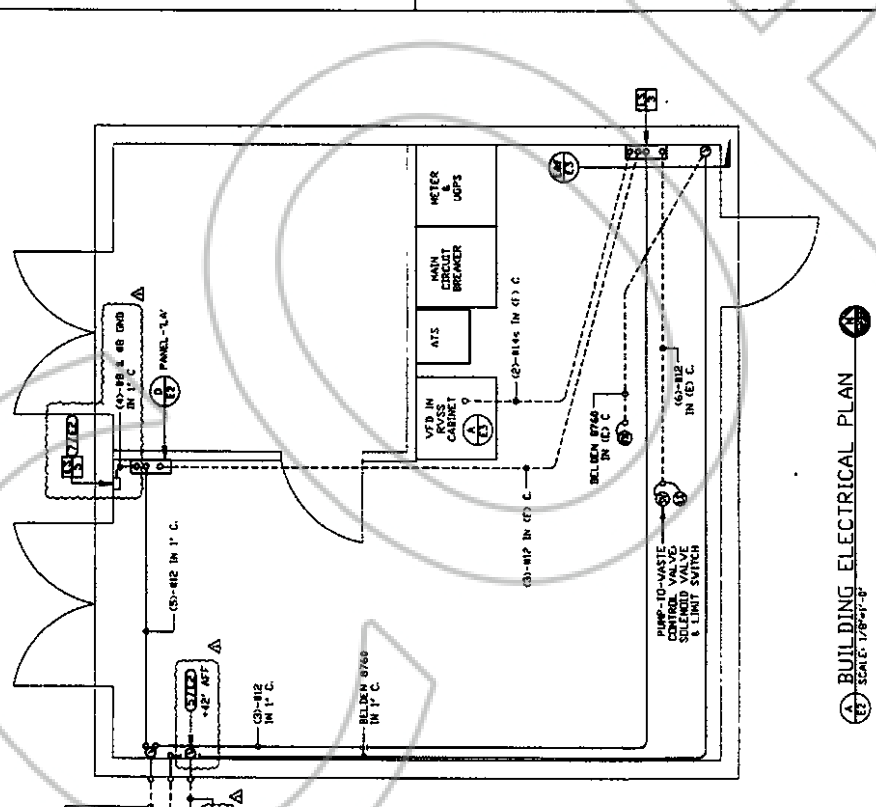

SHEET NOTES

- 1. PROVIDE AND INSTALL A 30-A 3-POLE 3-4-WIRE TRUCK-FILL BREAKER TO THE TRUCK-FILL PANEL.
- 2. VALUING AND CONNECT TRVS ADJACENT TO EXISTING PANEL.
- 3. PROVIDE AND INSTALL 40A 3-POLE CIRCUIT BREAKER FOR NEW TRVS SUBCIRCUIT.
- 4. PROVIDE AND INSTALL A 30-A 3-POLE 3-4-WIRE TRUCK-FILL BREAKER TO THE TRUCK-FILL PANEL.
- 5. VALUING AND CONNECT TRVS ADJACENT TO EXISTING PANEL.
- 6. PROVIDE AND INSTALL 40A 3-POLE CIRCUIT BREAKER FOR NEW TRVS SUBCIRCUIT.
- 7. PROVIDE AND INSTALL A 30-A 3-POLE 3-4-WIRE TRUCK-FILL BREAKER TO THE TRUCK-FILL PANEL.
- 8. VALUING AND CONNECT TRVS ADJACENT TO EXISTING PANEL.
- 9. PROVIDE AND INSTALL 40A 3-POLE CIRCUIT BREAKER FOR NEW TRVS SUBCIRCUIT.
- 10. PROVIDE AND INSTALL A 30-A 3-POLE 3-4-WIRE TRUCK-FILL BREAKER TO THE TRUCK-FILL PANEL.
- 11. VALUING AND CONNECT TRVS ADJACENT TO EXISTING PANEL.
- 12. PROVIDE AND INSTALL 40A 3-POLE CIRCUIT BREAKER FOR NEW TRVS SUBCIRCUIT.
- 13. PROVIDE AND INSTALL A 30-A 3-POLE 3-4-WIRE TRUCK-FILL BREAKER TO THE TRUCK-FILL PANEL.
- 14. VALUING AND CONNECT TRVS ADJACENT TO EXISTING PANEL.
- 15. PROVIDE AND INSTALL 40A 3-POLE CIRCUIT BREAKER FOR NEW TRVS SUBCIRCUIT.
- 16. PROVIDE AND INSTALL A 30-A 3-POLE 3-4-WIRE TRUCK-FILL BREAKER TO THE TRUCK-FILL PANEL.
- 17. VALUING AND CONNECT TRVS ADJACENT TO EXISTING PANEL.
- 18. PROVIDE AND INSTALL 40A 3-POLE CIRCUIT BREAKER FOR NEW TRVS SUBCIRCUIT.
- 19. PROVIDE AND INSTALL A 30-A 3-POLE 3-4-WIRE TRUCK-FILL BREAKER TO THE TRUCK-FILL PANEL.
- 20. VALUING AND CONNECT TRVS ADJACENT TO EXISTING PANEL.
- 21. PROVIDE AND INSTALL 40A 3-POLE CIRCUIT BREAKER FOR NEW TRVS SUBCIRCUIT.
- 22. PROVIDE AND INSTALL A 30-A 3-POLE 3-4-WIRE TRUCK-FILL BREAKER TO THE TRUCK-FILL PANEL.
- 23. VALUING AND CONNECT TRVS ADJACENT TO EXISTING PANEL.
- 24. PROVIDE AND INSTALL 40A 3-POLE CIRCUIT BREAKER FOR NEW TRVS SUBCIRCUIT.
- 25. PROVIDE AND INSTALL A 30-A 3-POLE 3-4-WIRE TRUCK-FILL BREAKER TO THE TRUCK-FILL PANEL.
- 26. VALUING AND CONNECT TRVS ADJACENT TO EXISTING PANEL.
- 27. PROVIDE AND INSTALL 40A 3-POLE CIRCUIT BREAKER FOR NEW TRVS SUBCIRCUIT.
- 28. PROVIDE AND INSTALL A 30-A 3-POLE 3-4-WIRE TRUCK-FILL BREAKER TO THE TRUCK-FILL PANEL.
- 29. VALUING AND CONNECT TRVS ADJACENT TO EXISTING PANEL.
- 30. PROVIDE AND INSTALL 40A 3-POLE CIRCUIT BREAKER FOR NEW TRVS SUBCIRCUIT.
- 31. PROVIDE AND INSTALL A 30-A 3-POLE 3-4-WIRE TRUCK-FILL BREAKER TO THE TRUCK-FILL PANEL.
- 32. VALUING AND CONNECT TRVS ADJACENT TO EXISTING PANEL.
- 33. PROVIDE AND INSTALL 40A 3-POLE CIRCUIT BREAKER FOR NEW TRVS SUBCIRCUIT.
- 34. PROVIDE AND INSTALL A 30-A 3-POLE 3-4-WIRE TRUCK-FILL BREAKER TO THE TRUCK-FILL PANEL.
- 35. VALUING AND CONNECT TRVS ADJACENT TO EXISTING PANEL.
- 36. PROVIDE AND INSTALL 40A 3-POLE CIRCUIT BREAKER FOR NEW TRVS SUBCIRCUIT.
- 37. PROVIDE AND INSTALL A 30-A 3-POLE 3-4-WIRE TRUCK-FILL BREAKER TO THE TRUCK-FILL PANEL.
- 38. VALUING AND CONNECT TRVS ADJACENT TO EXISTING PANEL.
- 39. PROVIDE AND INSTALL 40A 3-POLE CIRCUIT BREAKER FOR NEW TRVS SUBCIRCUIT.
- 40. PROVIDE AND INSTALL A 30-A 3-POLE 3-4-WIRE TRUCK-FILL BREAKER TO THE TRUCK-FILL PANEL.
- 41. VALUING AND CONNECT TRVS ADJACENT TO EXISTING PANEL.
- 42. PROVIDE AND INSTALL 40A 3-POLE CIRCUIT BREAKER FOR NEW TRVS SUBCIRCUIT.
- 43. PROVIDE AND INSTALL A 30-A 3-POLE 3-4-WIRE TRUCK-FILL BREAKER TO THE TRUCK-FILL PANEL.
- 44. VALUING AND CONNECT TRVS ADJACENT TO EXISTING PANEL.

FUEL STATION DETAIL

SCALE: 1/4"=1'-0"

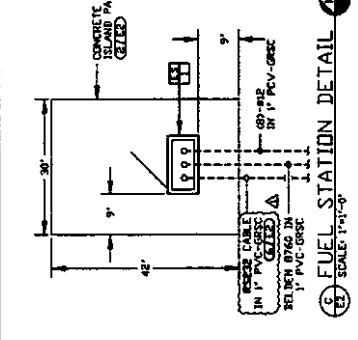

TRENCH SECTION

SCALE: 1/4"=1'-0"

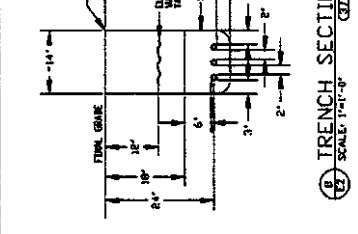

NO.	REV.	DATE	BY	CHKD.

Manhard
CONSULTING LTD.
100-21 144-23
100-21 144-23

NORTH DOUGLAS COUNTY - CARBON CITY
WATER LINE INTER-TIE PROJECT PHASE I - SECTION I
ELECTRICAL DIAGRAMS & ELEVATIONS

3 OF 3

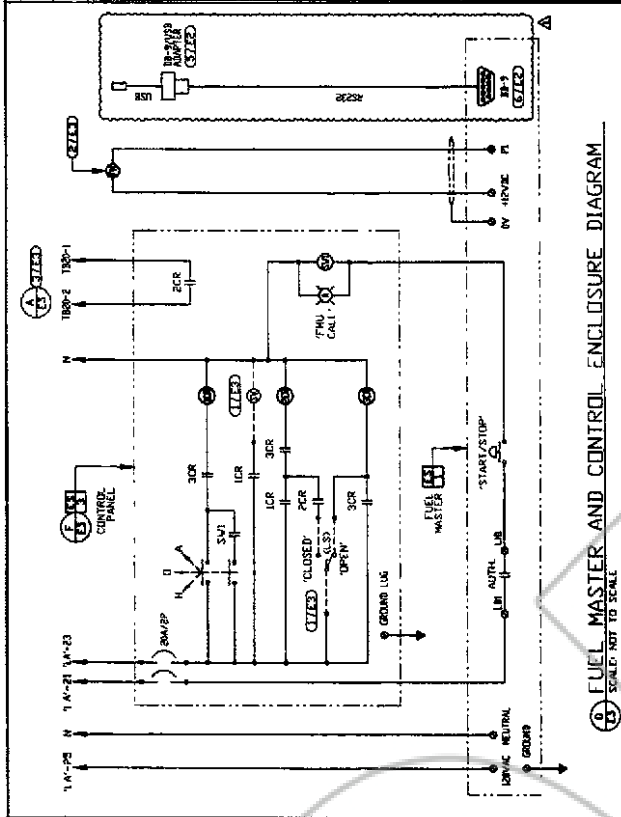

6 FUEL MASTER AND CONTROL ENCLOSURE DIAGRAM
SCALE: NOT TO SCALE

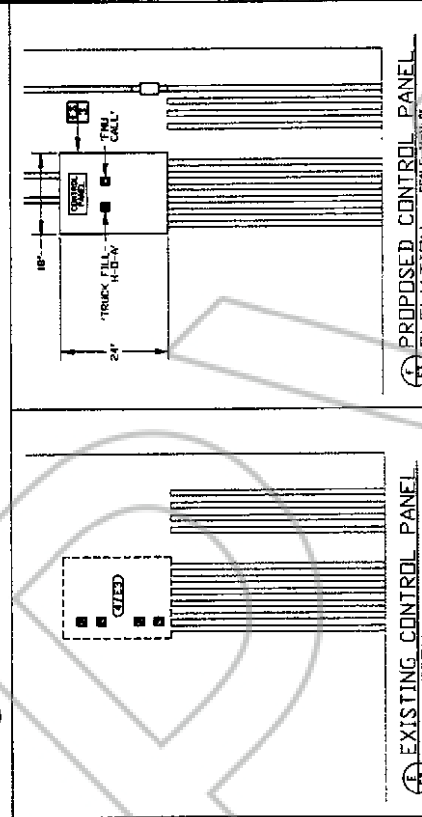

7 EXISTING CONTROL PANEL ELEVATION
SCALE: 1/4\"/>

8 PROPOSED CONTROL PANEL ELEVATION
SCALE: 1/4\"/>

SHEET NOTES

- RE-USE THE EXISTING WELL-HOUSE PUMP-TO-WASTE CONTROL VALVE SLEWED AND LIMIT SWITCH IN CONJUNCTION WITH NEW TRUCK FILL STATION.
- RE-USE THE EXISTING WELL-HOUSE FLOW-METER TRUCK FILL SIGNAL IN CONJUNCTION WITH NEW TRUCK FILL SIGNAL.
- RE-USE THE EXISTING MASTER BREAKER TRIP UNIT AND REPLACE WITH A NEW 500A TRUCK FILL TRIP UNIT.
- REMOVE EXISTING TRUCK FILL CONTROL PANEL AND REPLACE WITH NEW EQUIPMENT.
- REMOVE EXISTING 400A 3-POLE CIRCUIT BREAKER TRIP UNIT AND REPLACE WITH A NEW 500A TRUCK FILL TRIP UNIT.

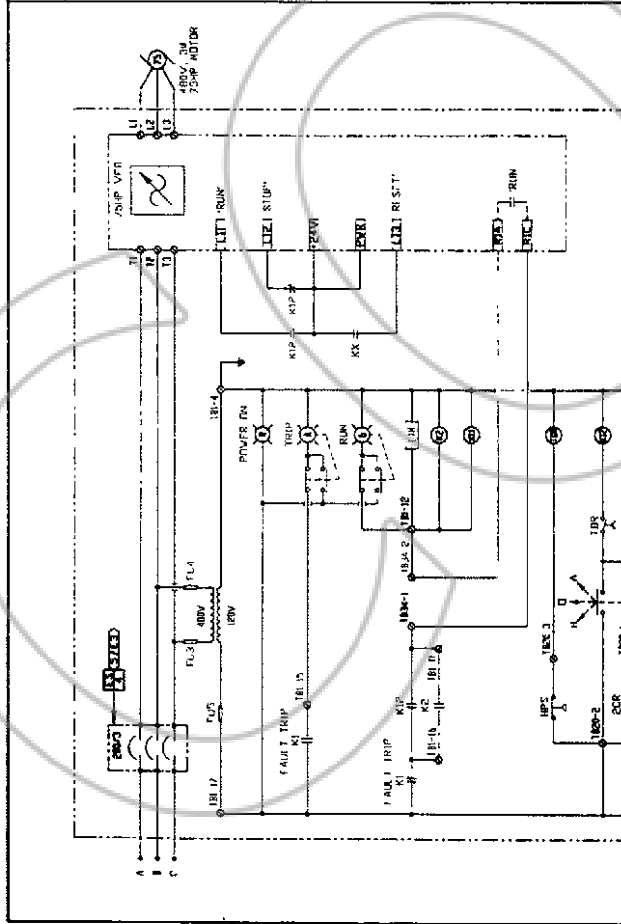

9 MODIFICATIONS TO EXISTING STARTER/VFD CONTROL
SCALE: NOT TO SCALE

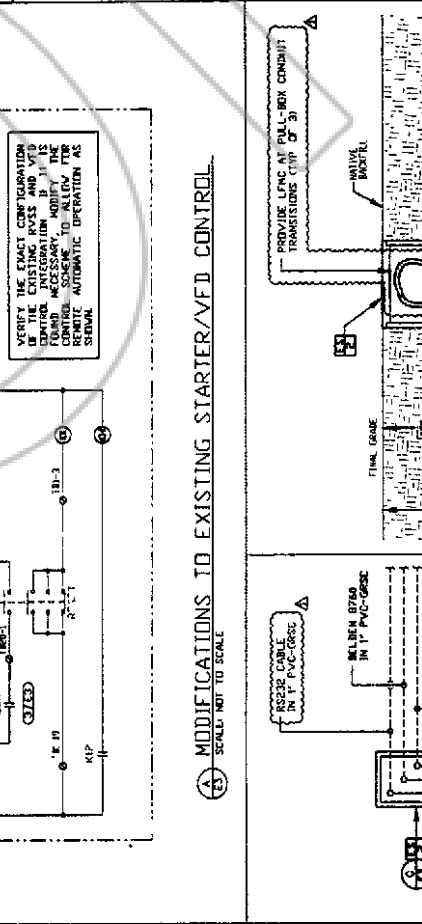

10 PULL BOX SECTION
SCALE: 1/4\"/>

11 PULL BOX DETAIL
SCALE: 1/4\"/>

Attachment to Change Order No. 15
N. Douglas County – Carson City Water Line Inter-Tie Project, Phase 1, Section 1
PWP-DO-2010-358

COPY

Item3
Demobilization/Remobilization



Q & D CONSTRUCTION, INC.

DEVELOPMENT | BUILDING | GENERAL ENGINEERING | TENANT IMPROVEMENTS | MILLWORK

November 2, 2011

1594 Esmeralda Ave.
P.O. Box 218
Minden, NV 89423

RE: Demobilization and Re-mobilization Costs

Dear Mr. Ron Roman,

Please see below for the cost impact to Q&D, and the attached for back-up information. Remobilization to project, pre-construction meeting and transporting equipment to and from project.

Labor:	\$	14,796.63
Equipment:	\$	10,654.12
Materials:	\$	1,010.00
Subs:	\$	3,310.00
Total:	\$	<u>29,770.75</u>

Q&D will except the agreed amount of \$29,300.00 for these documented costs.

Best Regards,

Doug Elder
Estimator / Project Manager
Q & D Construction, Inc.

TEL: 775-786-2677
FAX: 775-786-5136

P.O. BOX 10865, RENO, NV 89510
1050 S. 21ST STREET, SPARKS, NV 89431

NCL: 8197A&B
CCL: 427988BA

**No. Douglas Co.-Carson City Inter-tle
JOB # 12227
DAILY CALCULATION SHEET**



DATE PERFORMED: July 26th & August 1st **DESCRIPTION:** Remobilization to Project
DATE OF REPORT: November 1, 2011 Preparation to re-start

TOTAL OF EQUIPMENT:	\$ 9,094.12	TOTAL THIS REPORT
TOTAL OF LABOR:	\$ 9,114.48	
TOTAL OF SUBCONTRACTORS:	\$ 2,180.00	
TOTAL OF MATERIAL AND/OR WORK:	\$ 575.00	20,933.57

HRLY RATE + 15%	EQUIPMENT	HOURS	TOTALS
\$ 94.32	986G II Loaders	20.0	\$ 1,888.42
\$ 178.24	EV460BLC Excavator	10.0	\$ 1,762.38
\$ 133.03	EC360B LC Excavator	10.0	\$ 1,330.32
\$ 110.33	EC290B LC Excavator		\$ -
\$ 42.49	420D Backhoe	10.0	\$ 424.89
\$ 126.76	14H Blade	10.0	\$ 1,267.60
\$ 138.99	D7 Dozer		\$ -
\$ 47.92	Forklift	10.0	\$ 479.22
\$ 4.79	3" Pump		\$ -
\$ 44.93	Compactor - walk along	10.0	\$ 449.30
\$ 37.46	Hand Compactor - wacker	10.0	\$ 374.57
\$ 17.70	Foreman Pickup	10.0	\$ 177.00
\$ 47.12	10 Wheelers - Trucks	20.0	\$ 942.42
\$ 61.19	Water Truck		\$ -
\$ 71.30	Double Transfer Trucks		\$ -
\$ 35.41	Flat Bed Truck		\$ -
\$ 115.00	Boom Truck		\$ -
\$ 5.92	Air Compressor		\$ -
\$ 80.50	Welding Truck		\$ -
\$ 166.75	Welder w/ truck/equipt		\$ -
\$ 85.00	Transport		\$ -
			\$ -
			\$ -
			\$ -
			\$ -

HRLY RATE + 15%	LABOR RATES	HOURS	TOTALS
\$94.30	Superintendent	9.0	\$ 848.70
\$141.45	Superintendent OT		\$ -
\$68.44	Foreman	15.0	\$ 1,041.60
\$98.16	Foreman OT		\$ -
\$52.24	Carpenter		\$ -
\$68.90	Carpenter OT		\$ -
\$84.95	Equipment Operator	60.0	\$ 3,897.00
\$86.57	Operator OT		\$ -
\$42.98	Laborer	40.0	\$ 1,718.40
\$58.37	Laborer OT		\$ -
\$38.08	Flagger		\$ -
\$50.79	Flagger OT		\$ -
\$48.25	Truck Driver	25.0	\$ 1,206.25
\$48.77	Truck Driver OT		\$ -
\$61.44	Welder		\$ -
\$81.88	Welder OT		\$ -
\$80.50	Project Manager	5.0	\$ 402.50
\$57.50	Project Engineer		\$ -
			\$ -
			\$ -

MATERIALS + 15%	INVOICED AMOUNT	+ 15%	TOTALS
Titan Supply	\$ 500.00	\$ 75.00	\$ 575.00
SWPPP Materials		\$ -	\$ -
		\$ -	\$ -
		\$ -	\$ -
		\$ -	\$ -
		\$ -	\$ -

HRLY RATE + 5%	SUBCONTRACTORS	HOURS	TOTALS
\$ 145.00	WO Pipeline	10.0	\$ 1,450.00
\$ 700.00	C&C Fencing	1.0	\$ 700.00
			\$ -
			\$ -
			\$ -
			\$ -
			\$ -

FOREMAN SIGNATURE

OWNERS REPRESENTATIVE

**No. Douglas Co.-Carson City Inter-tle
JOB # 12227
DAILY CALCULATION SHEET**



DATE PERFORMED: July 26th
DESCRIPTION: Pre-construction Meeting
DATE OF REPORT: November 1, 2011
In main office - Covered Wagon Room

TOTAL OF EQUIPMENT:	\$	-	TOTAL THIS REPORT
TOTAL OF LABOR:	\$	4,822.12	
TOTAL OF SUBCONTRACTORS:	\$	1,160.00	
TOTAL OF MATERIAL AND/OR WORK:	\$	-	5,682.12

HRLY RATE + 15%	EQUIPMENT	HOURS	TOTALS
\$ 94.32	968G II Loaders	\$ -	
\$ 176.24	EV460BLC Excavator	\$ -	
\$ 133.03	EC360B LC Excavator	\$ -	
\$ 110.33	EC290B LC Excavator	\$ -	
\$ 42.49	420D Backhoe	\$ -	
\$ 126.76	14H Blade	\$ -	
\$ 138.99	D7 Dozer	\$ -	
\$ 47.92	Forklift	\$ -	
\$ 4.79	3" Pump	\$ -	
\$ 44.83	Compactor - walk along	\$ -	
\$ 37.48	Hand Compactor - wacker	\$ -	
\$ 17.70	Foreman Pickup	\$ -	
\$ 47.12	10 Wheelers - Trucks	\$ -	
\$ 61.19	Water Truck	\$ -	
\$ 71.30	Double Transfer Trucks	\$ -	
\$ 35.41	Flat Bed Truck	\$ -	
\$ 115.00	Boom Truck	\$ -	
\$ 5.92	Air Compressor	\$ -	
\$ 80.50	Welding Truck	\$ -	
\$ 166.75	Welder w/ truck/equipt Non-certified	\$ -	
\$ 65.00	Transport	\$ -	
		\$ -	
		\$ -	
		\$ -	
		\$ -	

HRLY RATE + 15%	LABOR RATES	HOURS	TOTALS
\$94.30	Superintendent	5.0	\$ 471.50
\$141.45	Superintendent OT		\$ -
\$69.44	Foreman	5.0	\$ 347.20
\$98.16	Foreman OT		\$ -
\$52.24	Carpenter		\$ -
\$69.80	Carpenter OT		\$ -
\$64.95	Equipment Operator	16.0	\$ 1,039.20
\$88.67	Operator OT		\$ -
\$42.86	Laborer	32.0	\$ 1,374.72
\$56.37	Laborer OT		\$ -
\$38.08	Flagger		\$ -
\$50.79	Flagger OT		\$ -
\$48.25	Truck Driver	16.0	\$ 772.00
\$48.77	Truck Driver OT		\$ -
\$61.44	Welder		\$ -
\$61.86	Welder OT		\$ -
\$80.50	Project Manager	5.0	\$ 402.50
\$57.50	Project Engineer	2.0	\$ 115.00
			\$ -
			\$ -

MATERIALS + 15%	INVOICED AMOUNT	+ 15%	TOTALS
		\$ -	\$ -
		\$ -	\$ -
		\$ -	\$ -
		\$ -	\$ -
		\$ -	\$ -
		\$ -	\$ -
		\$ -	\$ -
		\$ -	\$ -

HRLY RATE + 5%	SUBCONTRACTORS	HOURS	TOTALS
\$ 145.00	WO Pipeline	8.0	\$ 1,160.00
			\$ -
			\$ -
			\$ -
			\$ -
			\$ -
			\$ -
			\$ -

FOREMAN SIGNATURE

OWNERS REPRESENTATIVE

**No. Douglas Co.-Carson City Inter-tie
JOB # 12227
DAILY CALCULATION SHEET**



DATE PERFORMED: July 28th & 27th DESCRIPTION: Transporting Equipment back
DATE OF REPORT: November 1, 2011 to project, after ground conditions improved

TOTAL OF EQUIPMENT:	\$ 1,560.00	TOTAL THIS REPORT	
TOTAL OF LABOR:	\$ 1,180.08		
TOTAL OF SUBCONTRACTORS:	\$ 435.00		3,155.08
TOTAL OF MATERIAL AND/OR WORK:	\$ -		

HRLY RATE + 15%	EQUIPMENT	HOURS	TOTALS
\$ 94.32	886G II Loaders		\$ -
\$ 176.24	EV460BLC Excavator		\$ -
\$ 133.03	EC360B LC Excavator		\$ -
\$ 110.33	EC290B LC Excavator		\$ -
\$ 42.49	420D Backhoe		\$ -
\$ 126.76	14H Blade		\$ -
\$ 138.99	D7 Dozer		\$ -
\$ 47.92	Forklift		\$ -
\$ 4.79	3" Pump		\$ -
\$ 44.93	Compactor - walk along		\$ -
\$ 37.48	Hand Compactor - wacker		\$ -
\$ 17.70	Foreman Pickup		\$ -
\$ 47.12	10 Wheelers - Trucks		\$ -
\$ 61.19	Water Truck		\$ -
\$ 71.30	Double Transfer Trucks		\$ -
\$ 35.41	Flat Bed Truck		\$ -
\$ 115.00	Boom Truck		\$ -
\$ 5.92	Air Compressor		\$ -
\$ 80.50	Welding Truck		\$ -
\$ 166.75	Welder w/ truck/equipt		\$ -
	Non-certified		\$ -
\$ 65.00	Transport	24.0	\$ 1,560.00
			\$ -
			\$ -
			\$ -
			\$ -

HRLY RATE + 15%	LABOR RATES	HOURS	TOTALS
\$84.30	Superintendent		\$ -
\$141.45	Superintendent OT		\$ -
\$69.44	Foreman		\$ -
\$96.16	Foreman OT		\$ -
\$52.24	Carpenter		\$ -
\$69.90	Carpenter OT		\$ -
\$64.95	Equipment Operator		\$ -
\$88.57	Operator OT		\$ -
\$42.96	Laborer		\$ -
\$56.37	Laborer OT		\$ -
\$38.08	Flagger		\$ -
\$50.79	Flagger OT		\$ -
\$48.25	Truck Driver	20.0	\$ 665.00
\$48.77	Truck Dnver OT	4.0	\$ 195.08
\$81.44	Welder		\$ -
\$61.86	Welder OT		\$ -
\$80.50	Project Manager		\$ -
\$57.50	Project Engineer		\$ -
			\$ -
			\$ -

MATERIALS + 15%	INVOICED AMOUNT	+ 15%	TOTALS
		\$ -	\$ -
		\$ -	\$ -
		\$ -	\$ -
		\$ -	\$ -
		\$ -	\$ -
		\$ -	\$ -
		\$ -	\$ -

HRLY RATE + 5%	SUBCONTRACTORS	HOURS	TOTALS
\$ 145.00	WO Pipeline	3.0	\$ 435.00
			\$ -
			\$ -
			\$ -
			\$ -
			\$ -
			\$ -

FOREMAN SIGNATURE _____

OWNERS REPRESENTATIVE _____

Attachment to Change Order No. 15
N. Douglas County – Carson City Water Line Inter-Tie Project, Phase 1, Section 1
PWP-DO-2010-358

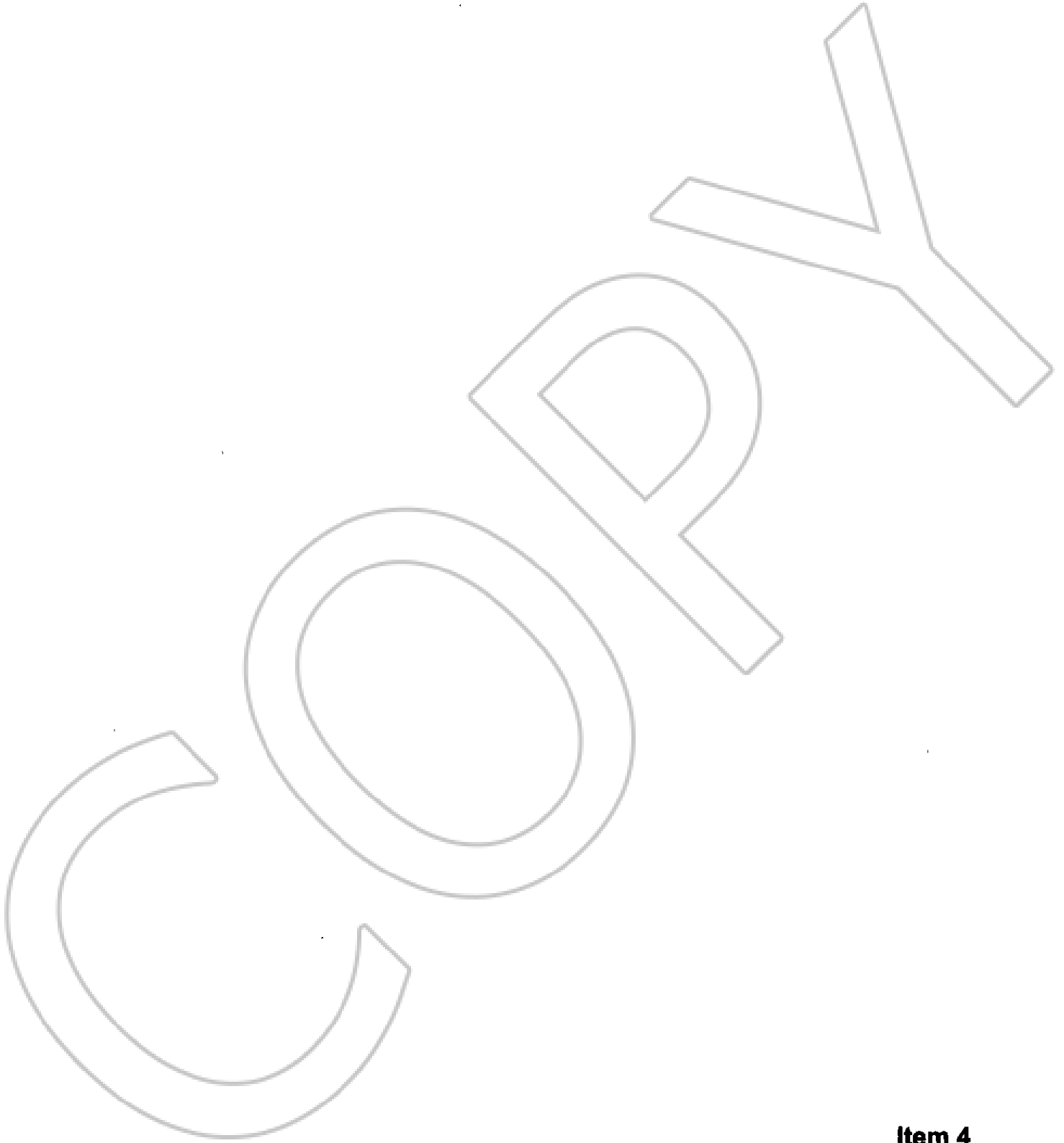

Item 4
Steel Plates



Q & D CONSTRUCTION, INC.

DEVELOPMENT | BUILDING | GENERAL ENGINEERING | TENANT IMPROVEMENTS | MILLWORK

November 2, 2011

1594 Esmeralda Ave.
P.O. Box 218
Minden, NV 89423

RE: Steel Plating for North end of project

Dear Mr. Ron Roman,

Please see below for the cost impact to Q&D, and the attached for back-up information. This is for process we needed to invoke to complete the north end of the project due to ground conditions.

Labor:	\$	1,483.10
Equipment:	\$	2,423.98
Materials:	\$	4,324.00
Subs:	\$	-
Total:	\$	<u>8,231.08</u>

Q&D will except the agreed amount of \$8,000.00 for these documented costs.

Best Regards,

Doug Eider
Estimator / Project Manager
Q & D Construction, Inc.

TEL: 775-786-2677
FAX: 775-786-5136

P.O. BOX 10865, RENO, NV 89510
1050 S. 21ST STREET, SPARKS, NV 89431

NCL: 8197A&B
CCL: 427988BA

No. Douglas Co.-Carson City Inter-tle
 JOB # 12227
 DAILY CALCULATION SHEET



DATE PERFORMED: August 1st to August 12th
 DATE OF REPORT: November 1, 2011

DESCRIPTION: Steel Flating process
 for the eight days affected

TOTAL OF EQUIPMENT:	\$ 2,423.88	TOTAL THIS REPORT	8,231.08
TOTAL OF LABOR:	\$ 1,483.10		
TOTAL OF SUBCONTRACTORS:	\$ -		
TOTAL OF MATERIAL AND/OR WORK:	\$ 4,324.00		

HRLY RATE + 15%	EQUIPMENT	HOURS	TOTALS
\$ 94.32	868G II Loaders		\$ -
\$ 176.24	EV460BLC Excavator	8.0	\$ 1,409.90
\$ 133.03	EC360B LC Excavator		\$ -
\$ 110.33	EC290B LC Excavator		\$ -
\$ 42.49	420D Backhoe		\$ -
\$ 126.76	14H Blade	8.0	\$ 1,014.08
\$ 138.99	D7 Dozer		\$ -
\$ 47.92	Forklift		\$ -
\$ 4.79	3" Pump		\$ -
\$ 44.93	Compactor - walk along		\$ -
\$ 37.46	Hand Compactor - wacker		\$ -
\$ 17.70	Foreman Pickup		\$ -
\$ 47.12	10 Wheelers - Trucks		\$ -
\$ 61.19	Water Truck		\$ -
\$ 71.30	Double Transfer Trucks		\$ -
\$ 35.41	Flat Bed Truck		\$ -
\$ 115.00	Boom Truck		\$ -
\$ 5.92	Air Compressor		\$ -
\$ 80.50	Welding Truck		\$ -
\$ 166.75	Welder w/ truck/equipt		\$ -
	Non-certified		\$ -
\$ 65.00	Transport		\$ -

HRLY RATE + 15%	LABOR RATES	HOURS	TOTALS
\$94.30	Superintendent	3.0	\$ 282.90
\$141.45	Superintendent OT		\$ -
\$69.44	Foreman		\$ -
\$98.16	Foreman OT		\$ -
\$52.24	Carpenter		\$ -
\$69.90	Carpenter OT		\$ -
\$84.95	Equipment Operator	16.0	\$ 1,039.20
\$88.57	Operator OT		\$ -
\$42.96	Laborer		\$ -
\$56.37	Laborer OT		\$ -
\$38.08	Flagger		\$ -
\$50.79	Flagger OT		\$ -
\$48.25	Truck Driver		\$ -
\$48.77	Truck Driver OT		\$ -
\$61.44	Welder		\$ -
\$81.66	Welder OT		\$ -
\$80.50	Project Manager	2.0	\$ 161.00
\$57.50	Project Engineer		\$ -
			\$ -
			\$ -

MATERIALS + 15%	INVOICED AMOUNT	+ 15%	TOTALS
United Rentals	\$ 3,760.00	\$ 564.00	\$ 4,324.00
18 Ea. Plates		\$ -	\$ -
		\$ -	\$ -
		\$ -	\$ -
		\$ -	\$ -
		\$ -	\$ -
		\$ -	\$ -

HRLY RATE + 6%	SUBCONTRACTORS	HOURS	TOTALS
			\$ -
			\$ -
			\$ -
			\$ -
			\$ -
			\$ -
			\$ -

FOREMAN SIGNATURE
 OWNERS REPRESENTATIVE

United Rentals

800-UR-RENTS (800-877-3687)
 unitedrentals.com

LOCATION #800
 12905 OLD VIRGINIA ROAD
 RENO, NV 89521
 775-348-0140 775-348-0133 FAX



RENTAL QUOTE

94563586

Customer Number	: 37922
Quote Date	: 7/20/11
Estimated Out	: 7/20/11 1:59 PM
Estimated In	: 8/17/11 1:59 PM
Job Location:	TBD, MINDEN
Job Number	: 182
P.O. Number	: PLATE QUOTE
Ordered By	: DOUG ELDER
Written By	: URBOOLF
Salesperson	: 6021

Job Site

DOUGLAS COUNTY NORTH TIE-IN
 TBD
 X: .@.
 MINDEN, NV 89423
 Office: 775-353-7070 Call: 775-786-2677

Customer

Q & D CONSTRUCTION
 1050 SOUTH 21ST STREET
 SPARKS, NV 89431

RENTAL ITEMS:		Minimum	Day	Week	4 Week	Estimated Amt.
Qty	Equipment Description					
26	944/9937 ROAD PLATE 8' X 16' X 1-1/2"	75.00	25.00	125.00	235.00	6,110.00
***** ALL EQUIPMENT MUST BE FREE OF DEBRIS IE: CEMENT, ASPHALT, WELDS, ROCKS, ETC OR SUBJECT TO A CLEANING CHARGE *****						
Rental Subtotal:						6,110.00
Agreement Subtotal:						6,110.00
Tax:						433.81
Estimated Total:						6,543.81

COMMENTS/NOTES:

Trucking at \$100/hour portal to portal
 As quoted, 6 deliveries & 6 pick-ups
 Plate weight 7882# per plate

TO SCHEDULE EQUIPMENT FOR PICKUP, CALL 800-UR-RENTS (800-877-3687)
 WE ARE AVAILABLE 24/7 TO SUPPLY YOU WITH A CONFIRMATION #
 IN ORDER TO CLOSE THIS CONTRACT

1,800.00 DELIVERY CHARGE

8,374.00

Note: This proposal may be withdrawn if not accepted within 30 days.

THIS IS NOT A RENTAL AGREEMENT. THE RENTAL OF EQUIPMENT AND ANY OTHER ITEMS LISTED ABOVE IS SUBJECT TO AVAILABILITY AND ACCEPTANCE OF THE TERMS AND CONDITIONS OF UNITED'S RENTAL AGREEMENT, WHICH MUST BE SIGNED PRIOR TO OR UPON DELIVERY OF THE EQUIPMENT AND OTHER ITEMS.

Attachment to Change Order No. 15
N. Douglas County – Carson City Water Line Inter-Tie Project, Phase 1, Section 1
PWP-DO-2010-358

COPY

Item 5
Contract Dates



COMMUNITY DEVELOPMENT

1594 Esmeralda Avenue, Minden, Nevada 89423

Mimi Moss

COMMUNITY DEVELOPMENT DIRECTOR

775-782-6201

FAX: 775-782-6297

website: www.douglascountynv.gov

Planning Division
Engineering Division
Building Division
Regional Transportation
Code Enforcement

July 27, 2011

Mr. Doug Elder
Project Manager
Q & D Construction, Inc.
P.O. Box 10865
Reno, NV 89510

RE: North End Construction Access- Steel Plating
Waterline Inter-tie Project
PWP-DO-2010-358

Dear Doug:

This letter is in response to your letter dated July 22, 2011 (C-028), to address the completion of the north end of the project (approximately 4000 feet of water main remaining).

In your letter, you provided your proposed strategy to access and complete the project by utilizing steel plating. The County is not opposed to this method of construction. Pursuant to General Condition 9.10 B of the Contract, however, I am not permitted to direct your means, methods or sequence of construction and cannot approve or disapprove your proposal. The County will consider your letter a notice of a potential claim as provided by the Contract.

Pursuant to Article 12 of the Contract Documents, at the conclusion of the applicable work, Q&D will need to submit a final Claim including the amount or extent of the Claim with supporting documentation to the County as required in Article 10.05 A of the Contract Documents for the County's consideration.

We have also received your proposed schedule to complete this project. Previously, the County proposed a revised Substantial Completion Date of August 17, 2011 and a revised Final Completion Date of August 31, 2011 to allow time for site conditions to dry out and improve. Your proposed schedule accommodates those dates and will also satisfy the State of Nevada's current Administrative Order to supply water to Indian Hills GID.

A change order to extend the Contract Times to these dates will be executed. However, due to the outstanding claims on this project that we have not yet been able to resolve, and the fact that the County will sustain additional costs due to the extension of time to the Contract, the County reserves all rights granted to it by the Contract related to the missed original Substantial Completion and Final Completion Dates. Notwithstanding the foregoing, it is my hope to work with you to resolve any unresolved issues and successfully complete the project.

Sincerely,

Donette Barreto

Donette Barreto, P.E.
Project Manager

cc: Carl Ruschmeyer, PE, Douglas County Public Works Director
Doug Ritchie, Deputy District Attorney

COPY

CERTIFIED COPY

The document to which this certificate is attached is a full, true and correct copy of the original on file and on record in my office.

DATE: Jan 31, 2012
TERRAN Clerk of the 97 Judicial District Court
of the State of Nevada, in and for the County of Douglas.
By Doug Ritchie Deputy