

Assessor's Parcel Number: N/A

Date: FEBRUARY 11, 2019

Recording Requested By:

Name: HEATHER MACDONNELL, PUBLIC WORKS

Address: \_\_\_\_\_

City/State/Zip: \_\_\_\_\_

Real Property Transfer Tax: \$ N/A



KAREN ELLISON, RECORDER

AMENDED CONTRACT #2019.023  
(Title of Document)

FILED

2019.023

**CONTRACT AMENDMENT NO. 001**

2019 FEB 11 AM 10:29

**A Contract Between Douglas County**

**And**

**Summit Plumbing Co.**

DOUGLAS COUNTY  
CLERK  
*[Signature]*

**For 1109 US HWY 50 Water Service Repair**

**WHEREAS**, on November 14, 2018, Douglas County, a political subdivision of the State of Nevada ("COUNTY"), and Summit Plumbing Co., an independent contractor ("INDEPENDENT CONTRACTOR") (hereinafter collectively referred to as "THE PARTIES"), entered into a contract for construction services in connection with the 1109 US HWY 50 Water Service Repair in an amount not to exceed \$35,682 29 ("CONTRACT"), and

**WHEREAS**, the County desires to modify the contract to have Independent Contractor install a concrete collar around the water meter installed in the driveway at 1109 US HWY 50, Zephyr Cove, NV

**NOW, THEREFORE**, in consideration of the agreements herein made, the parties mutually agree as follows

- 1 INDEPENDENT CONTRACTOR shall complete the following tasks
  - o Install a concrete collar around the water meter pit installed at 1109 US HWY 50 in accordance with the attached Exhibit A at a cost not to exceed \$875
- 2 The additional services set forth in paragraph 1, above shall be completed on a lump sum basis not to exceed a cost of \$875, and must be completed by May 30, 2019
- 3 The Contract amount of \$35,682 29 is changed to \$36,557 29
- 4 Except as specifically set forth herein, all of the terms and conditions of the original Contract remain unchanged by this amendment and remain in full effect

*[Signature]*  
\_\_\_\_\_  
Paul Kearney, Member  
Summit Plumbing Co

1/30/19  
Date

*[Signature]*  
\_\_\_\_\_  
Jennifer Davidson, Acting County Manager

1/30/19  
Date

Attest  
*[Signature]*  
\_\_\_\_\_  
County Clerk

2/8/19  
Date

24"Ø RING AND COVER BLANK OR W/"WATER" CAST IN TRAFFIC RATED LID

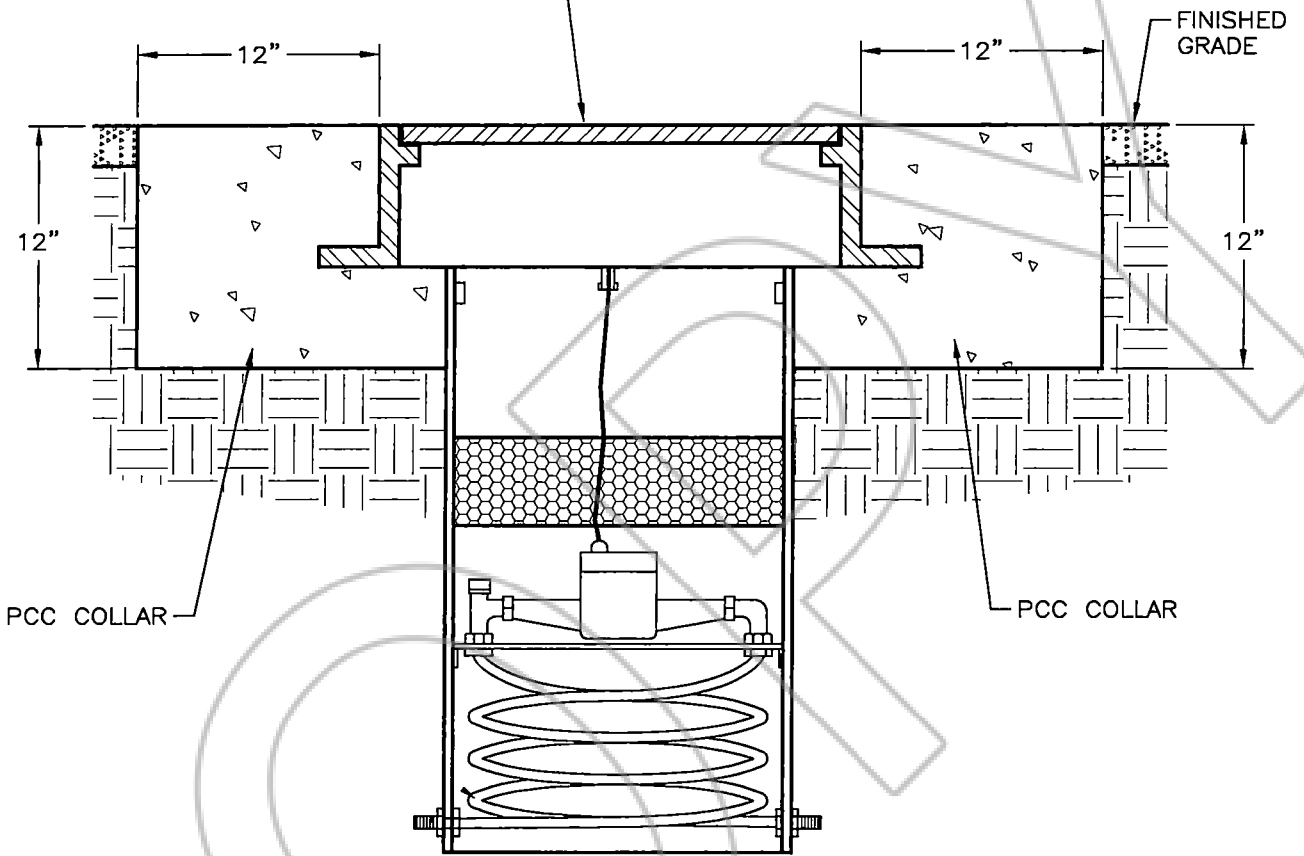

METER PIT PER DC-B02

Exhibit A

NO	REVISION	DATE	SECTION
			DATE
			DWG

**RING & COLLAR  
IN TRAFFIC AREA**

COPY

Douglas County

State of Nevada

CERTIFIED COPY

I certify that the document to which this certificate is attached is a full and correct copy of the original record on file in the Clerk-Treasurer's Office on this

15<sup>th</sup> day of July, 2019

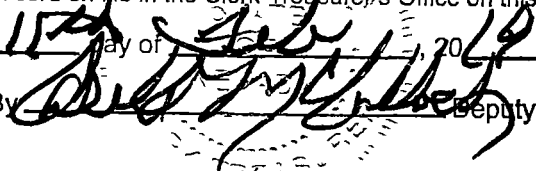
By  Deputy

