



00182940202410093190170172

SHAWNYNE GARREN, RECORDER

Recorder's Office Cover Sheet

Recording Requested By:

Name: Ryan Stanton

Department: Parks Department

Item ID/Agreement #: DC-657-2024

Type of Document: (please select one)

- Agreement
- Contract
- Grant
- Change Order
- Easement
- Other

specify: _____

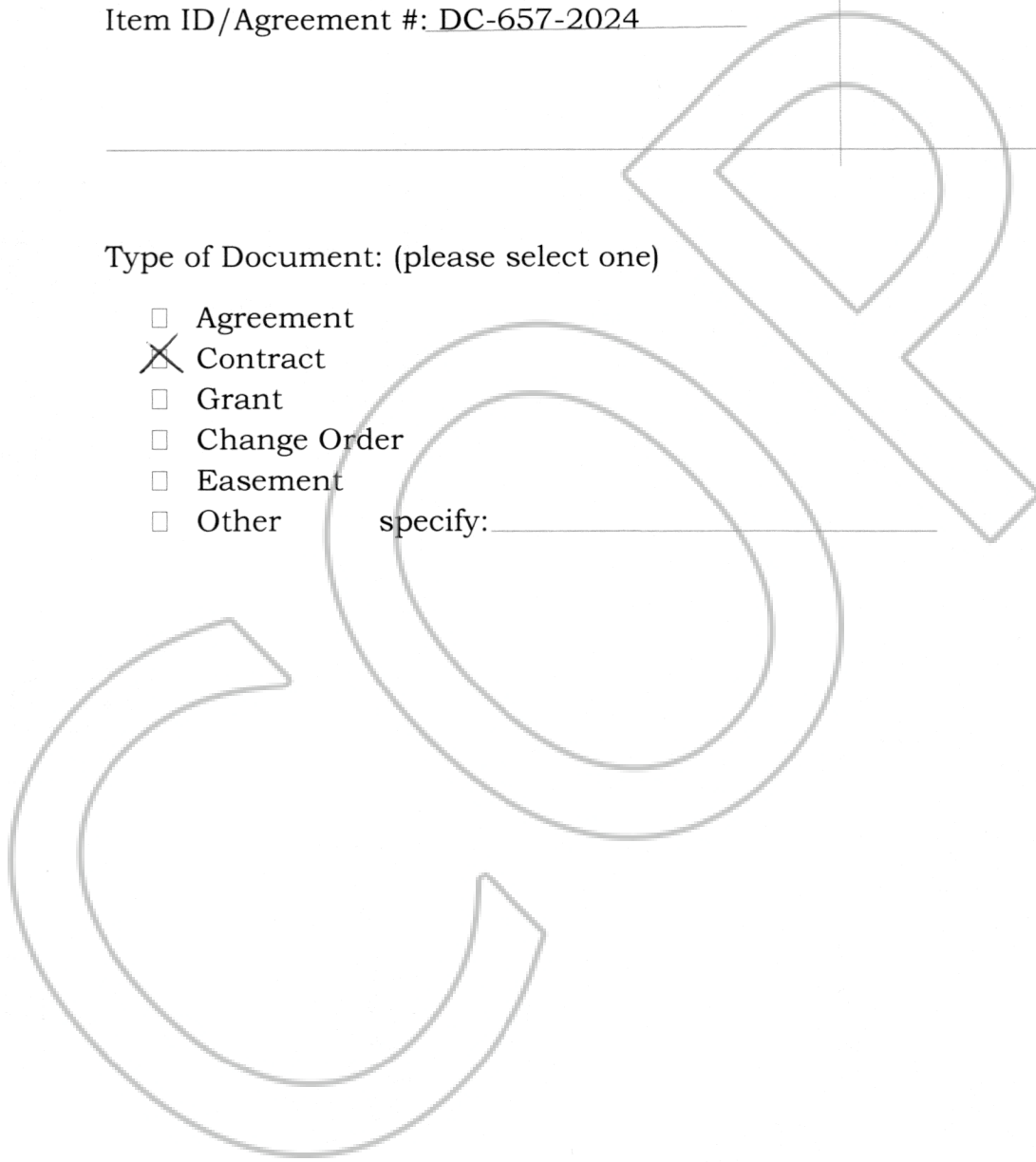

CONTRACT FOR SERVICES BY AN INDEPENDENT CONTRACTOR

A CONTRACT BETWEEN

DOUGLAS COUNTY, NEVADA

AND

CENTRAL SIERRA CONSTRUCTION, INC.

FILED

NO. DC-657-2024

6/21/24
DATE

DOUGLAS COUNTY CLERK
MINDEN, NV

BY [Signature] DEPUTY

This Contract for Services by an Independent Contractor (the “Contract”) is entered into by and between Douglas County, a political subdivision of the State of Nevada (the “County”), and Central Sierra Construction, Inc., a Nevada Domestic Corporation, *Nevada Business ID # NV 19921060188* (“Contractor”). The County and Contractor are at times collectively referred to hereinafter as the “Parties” or individually as the “Party.”

WHEREAS, Douglas County, a political subdivision of the State of Nevada, from time to time requires the services of independent contractors; and

WHEREAS, it is deemed that the services of Contractor herein specified are both necessary and desirable and in the best interests of Douglas County; and

WHEREAS, Contractor represents that Contractor is duly qualified, equipped, staffed, ready, willing and able to perform and render the services hereinafter described.

NOW, THEREFORE, in consideration of the mutual promises and covenants herein made, the County and Contractor mutually agree as follows:

1. TERM AND EFFECTIVE DATE OF CONTRACT. The Contract will become effective on the date it is signed by the last Party to sign the Contract (“Effective Date”). Unless earlier terminated as set forth in this Contract, the terms of this Contract shall remain in effect until the Services to be Performed under Paragraph 2 have been completed. Time is of the essence in this Contract.

2. SERVICES TO BE PERFORMED. The Parties agree that the Contractor will perform the following services: to provide all labor, equipment and materials to perform restoration work in compliance with the plans provided by TSK dated April 1, 2024 (“Services”). County will provide the lumber, drywall, paint, windows and roofing for the project. The Services are more particularly described and shall be completed in accordance with the requirements set forth in Attachment “A” hereto.

3. PAYMENT FOR SERVICES. Contractor agrees to provide the services set forth in Paragraph 2 on a time and materials basis for a total cost not to exceed \$49,700.00 (the “Contract Price”). Unless Contractor has received a written exemption from the County, Contractor shall submit monthly requests for payment for services performed under this Contract. Requests for payment shall be submitted no later than fifteen (15) days after the end of a month and must include

a detailed summary of the expenditures reported in a form that supports the approved budget. Specifically, Contractor agrees to provide with each request for payment a schedule of actual expenditures for the period, cumulative total expenditures for the entire Contract, and a comparison of cumulative total expenditures to the maximum expected fee for the services and tasks set forth in Paragraph 2. As a precondition to receiving any payment from the County, Contractor shall complete all required tax identification and vendor registration forms for the Douglas County Finance Department. Payment of uncontested fees will be made within thirty (30) days.

4. INDEPENDENT CONTRACTOR STATUS. The Parties agree that Contractor, its associates, employees and subcontractors shall have the status of independent contractors and that this Contract, by explicit agreement of the Parties, incorporates and applies the provisions of Nevada Revised Statutes (NRS) 333.700, as necessarily adapted to the Parties, including that Contractor is not a Douglas County employee and that there shall be no:

- 1) Withholding of income taxes by the County.
- 2) Industrial insurance coverage provided by the County.
- 3) Participation in group insurance plans which may be available to employees of the County.
- 4) Participation or contributions by either the independent contractor or the County to the public employees' retirement system.
- 5) Accumulation of vacation leave or sick leave.
- 6) Unemployment compensation coverage provided by the County.

Contractor and County agree to the following rights and obligations consistent with an independent contractor relationship between the Parties:

- a. Contractor has the right to perform services for others during the term of this Contract.
- b. Contractor has the sole right to control and direct the means, manner and method by which the services required by this Contract will be performed.
- c. Contractor shall not be assigned a work location on County premises.
- d. Contractor, at Contractor's sole expense, will furnish all equipment and materials used to provide the services required by this Contract.
- e. Contractor, at Contractor's sole expense, has the right to hire assistants as subcontractors, or to use Contractor's employees to provide the services required by this Contract.
- f. Contractor or Contractor's employees or contract personnel shall perform the services required by this Contract, and Contractor agrees to the faithful performance and delivery of described services in accordance with the time frames contained herein; County shall not hire, supervise or pay any assistants to help Contractor.
- g. Neither Contractor nor Contractor's employees or contract personnel shall receive any training from County in the skills necessary to perform the services required by this Contract.
- h. County shall not require Contractor or Contractor's employees or contract personnel to devote full time to performing the services required by this Contract.

- i. Contractor understands that Contractor is solely responsible to pay any federal and state taxes and/or any social security or related payments applicable to money received for services provided under the terms of this contract. Contractor understands that an IRS Form 1099 will be filed by County for all payments County makes to Contractor.

5. INDUSTRIAL INSURANCE. Contractor further agrees that, prior to the commencement of any work and as a precondition to any obligation of the County to make any payment under the Contract, Contractor will provide the County with a work certificate and/or a certificate issued by a qualified insurer in accordance with NRS 616B.627. Contractor also agrees that, prior to commencing any work under the Contract, Contractor will complete and provide evidence to the County that Contractor has made the following written request to Contractor's insurer:

Central Sierra Construction, Inc. has entered into a contract with Douglas County to perform services through August 31, 2024, and requests that an authorized insurer provide to Douglas County: (1) A certificate of coverage issued pursuant to NRS 616B.627 and (2) Notice of any lapse in coverage or nonpayment of coverage that the Contractor is required to maintain.

The certificate and notice should be mailed to:

Douglas County
Community Services
ATTN: Community Services Director
Post Office Box 218
Minden, Nevada 89423

Contractor agrees to maintain all required workers' compensation coverage throughout the entire term of the Contract. If Contractor does not maintain the required coverage throughout the entire term of the Contract, Contractor agrees that the County may, at any time the coverage is not maintained by Contractor, order the Contractor to stop work, suspend the Contract, or terminate the Contract at the sole discretion of the County. For each six-month period this Contract is in effect, Contractor agrees, prior to the expiration of the six-month period, to provide another written request to the insurer for the provision of a certificate and notice of lapse in, or nonpayment of, insurance coverage. If Contractor does not make the request or does not provide the certificate before the expiration of the six-month period, Contractor agrees that the County may order the Contractor to stop work, suspend the Contract, or terminate the Contract at the sole discretion of the County.

Contractor may, in lieu of furnishing a certificate of an insurer, provide an affidavit indicating that Contractor is a sole proprietor and that:

- A. In accordance with the provisions of NRS 616B.659, has not elected to be included within the terms, conditions and provisions of chapters 616A to 616D, inclusive, of NRS; and

B. Is otherwise in compliance with those terms, conditions and provisions

6. WARRANTY. Contractor agrees and hereby provides, warrants and represents each of the following with respect to any services provided under this Contract: the work performed under this Contract shall be free of defects in material and workmanship for a period of 365 days following the completion of such work and the work will be performed in a professional and workman like manner and in conformity with the professional standards for comparable services in the industry, and shall comply with the applicable specifications or other requirements set forth in this Contract. This term shall not be construed as a limitation on any other remedies that might be available to the County.

7. TERMINATION OF CONTRACT. Either Party may terminate the Contract for cause if the other Party fails to correct any breach of the terms of the Contract within 30 days after receiving notice of such breach and having been given a reasonable opportunity to cure the breach. County may terminate the contract without cause upon 30 days advanced written notice to the other. Provided, however, that except as otherwise set forth in this Contract, early termination will not relieve a Party of any obligation that became due prior to the date of termination.

8. LICENSING. Contractor agrees to maintain any required licenses and certifications to perform any services for County, including but not limited to a Nevada State Business license and a Nevada State Contractor's license. The failure to maintain any required license will result in immediate termination of this Contract. Contractor shall promptly inform County of any claims or complaints made against Contractor (or any of its employees or agents who are engaged in work under this Contract) to any professional licensing board or of any investigations conducted by such boards; in this context, promptly shall mean as soon as possible, but in no event later than five business days after Contractor becomes aware of the claim, complaint or investigation.

9. INSURANCE. Douglas County's liability coverage will not extend to the Contractor. Without limiting Contractor's indemnification of County as described in Section 19, Contractor shall obtain and maintain at its own expense during the term of this Contract, policies of liability insurance of the type and amounts described below. Such policies shall be signed by a person authorized by that insurer to bind coverage on its behalf.

The County and its elected officials, employees, agents, and volunteers shall be named as additional insureds under the policies required for all liability arising from Contractor's performance of work pursuant to this Contract. This provision shall also apply to any excess/umbrella liability policies. This insurance shall be primary to any insurance maintained by the County. County insurance shall not contribute to any judgment rendered against the County.

Prior to the commencement of any work under this Contract, Contractor shall provide to the County certificates of insurance with original endorsements of the following insurance coverage:

a. **General Liability Insurance.** Contractor is required to acquire and maintain general liability insurance in the minimum amount of \$1,000,000 per occurrence,

\$2,000,000 general aggregate, for bodily injury, personal injury, and property damage during the term of this Contract at Contractor's sole expense. Proof of insurance must be sent to the Douglas County Manager. Such proof of insurance must be provided at least annually throughout the term of this Contract and Douglas County must be notified at least 30 days in advance of any cancellation or nonrenewal of such insurance.

b. **Automobile Liability Insurance.** Contractor is required to acquire and maintain automobile insurance covering bodily injury and property damage for all activities of the Contractor arising out of or in connection with the work to be performed under this Contract, including coverage for any owned, hired, non-owned or rented vehicles, in an amount not less than \$1,000,000 combined single limit for each accident.

All insurance coverage maintained or procured pursuant to this Contract shall be endorsed to waive subrogation against County, its elected officials, employees, agents, and volunteers or shall specifically allow Contractor or others providing insurance evidence in compliance with these specifications to waive their right of recovery prior to a loss. Contractor hereby waives its own right of recovery against County and shall require similar written express waivers and insurance clauses from each of its subcontractor(s).

Coverage provided by Contractor shall be primary and any insurance or self-insurance procured or maintained by County shall not be required to contribute with it. The limits of insurance required herein may be satisfied by a combination of primary and umbrella or excess insurance. Any umbrella or excess insurance shall contain or be endorsed to contain a provision that such coverage shall also apply on a primary and non-contributory basis for the benefit of the County before the County's own insurance or self-insurance shall be called upon to protect it as a named insured.

Requirements of specific coverage features, or limits contained in this Contract are not intended as a limitation on coverage, limits or other requirements, or a waiver of any coverage normally provided by any insurance. Specific reference to a given coverage feature is for purposes of clarification only as it pertains to a given issue and is not intended by any Party or insured to be all inclusive, or to the exclusion of other coverage, or a waiver of any type. If the Contractor maintains higher limits than the minimums shown above, the County requires and shall be entitled to coverage for the higher limits maintained by the Contractor. Any available insurance proceeds in excess of the specified minimum limits of insurance and coverage shall be available to the County.

None of the coverages required herein will be in compliance with these requirements if they include any limiting endorsements of any kind that has not been first submitted to County and approved in writing.

A severability of interests provision must apply for all additional insureds ensuring that Contractor's insurance shall apply separately to each insured against whom claim is made or suit is brought, except with respect to the insurer's limits of liability. The policies shall not contain cross-liability exclusions.

Contractor agrees to ensure that its subcontractor(s), and any other party involved with the project who is brought onto or involved in the project by the Contractor, provide the same minimum insurance coverage and endorsements required of Contractor. Contractor agrees to monitor and review all such coverage and assumes all responsibility for ensuring that such coverage is provided in conformity with the requirements of this Contract.

Any self-insured retentions must be declared to and approved by the County. County reserves the right to require that self-insured retentions be eliminated, lowered, or replaced by a deductible. Self-insurance will not be considered to comply with these specifications unless approved by County.

Contractor shall give County prompt and timely notice of claims made or suits instituted that arise out of or result from Contractor's performance under this Contract, and that involve or may involve coverage under any of the required liability policies.

Contractor shall procure and maintain, at its own cost and expense, any additional kinds of insurance, which in its own judgment may be necessary for its proper protection and prosecution of the work to be performed under this Contract.

10. NONAPPROPRIATION. All payments required pursuant to the Contract are contingent upon the availability of County funds. In accordance with NRS 354.626 and any other applicable provision of law, the financial obligations between the Parties will not exceed those monies appropriated and approved by the County for the Contract for the then current fiscal year under the Local Government Budget Act. The Contract will terminate and the County's obligations will be extinguished if the County fails to appropriate the necessary funding.

Nothing in the Contract will be construed to provide Contractor with a right of payment from any entity other than the County. Any funds budgeted by the County pursuant to the terms of the Contract that are not paid to Contractor will automatically revert to the County's discretionary control upon the completion, termination, or cancellation of the Contract. The County will not have any obligation to re-award or to provide, in any manner, the unexpended funds to Contractor. Contractor will have no claim of any sort to the unexpended funds.

11. CONSTRUCTION OF CONTRACT. The Contract will be construed and interpreted according to the laws of the State of Nevada. There will be no presumption for or against the drafter in interpreting or enforcing the Contract. The Contract Documents consist of this document, and Attachment A. The Parties agree to be bound by the terms, conditions and specifications set forth in all Contract Documents, except as specifically modified or amended. The terms of the Contract Documents shall, to the extent reasonably practical, be read as complimentary to one another. In the event of an irreconcilable conflict between the terms of the Contract Documents, the terms of this document shall prevail, thereafter the terms of Attachment A.

12. DISPUTE RESOLUTION. In the event a dispute arises between the Parties, the Parties promise and agree to first meet and confer to resolve any dispute. If such meeting does

not resolve the dispute, then the Parties agree to mediate any dispute arising from or relating to the Contract before an independent mediator mutually agreed to by the parties. The fee, rate or charge of the mediator will be shared equally by the Parties, who will otherwise be responsible for their own attorney's fees and costs. If mediation is unsuccessful, litigation may only proceed before a department of the Ninth Judicial Court of the State of Nevada in and for the County of Douglas that was not involved in the mediation process and attorney's fees and costs will be awarded to the prevailing party at the discretion of the court.

13. COMPLIANCE WITH APPLICABLE LAWS. Contractor promises and agrees to fully and completely comply with all applicable local, state and federal laws, regulations, orders, or requirements of any sort in carrying out the obligations of the Contract, including, but not limited to, all federal, state, and local accounting procedures and requirements, all hazardous materials regulations, and all immigration and naturalization laws.

14. NONDISCRIMINATION. In accordance with Title VI of the Civil Rights Act of 1964, as amended, 42 U.S.C. § 2000d, Section 303 of the Age Discrimination Act of 1975, as amended, 42 U.S.C. § 6102, Section 202 of the Americans with Disabilities Act of 1990, 42 U.S.C. § 12132, 49 U.S.C. § 5332, and any other applicable Federal or State non-discrimination laws, the Contractor agrees that it will not unlawfully discriminate on the basis of race, color, creed, national origin, sex, age, or disability in the performance of this Contract.

15. ASSIGNMENT. Contractor will neither assign, transfer nor delegate any rights, obligations or duties under the Contract without the prior written consent of the County.

16. COUNTY INSPECTION. The books, records, documents and accounting procedures and practices of Contractor related to the Contract will be subject to inspection, examination and audit by the County, including, but not limited to, the contracting agency, the County Manager, the District Attorney, and, if applicable, the Comptroller General of the United States, or any authorized representative of those entities.

17. DISPOSITION OF CONTRACT MATERIALS. Any books, reports, studies, photographs, negatives or other documents, data, drawings or other materials prepared by or supplied to Contractor in the performance of its obligations under the Contract (the "Materials") will be the exclusive property of the County and all such materials will be remitted and delivered, at Contractor's expense, to the County by Contractor upon the completion, termination or cancellation of the contract. Alternatively, if the County provides its written approval to Contractor, the Materials must be retained by Contractor for a minimum of six years after Contractor's receipt of the final payment from County and all other pending matters are closed. If, at any time during the retention period, the County, in writing, requests any or all of the Materials, then Contractor will promptly remit and deliver the materials, at Contractor's expense, to the County. Unless the County has requested the remittance and delivery by Contractor of the Materials, Contractor will not use, willingly allow or cause to have such Materials used for any purpose other than the performance of Contractor's obligations under the terms of the Contract without the prior written consent of the County.

18. PUBLIC RECORDS LAW. Contractor expressly understands and agrees that all documents submitted, filed, or deposited with the County by Contractor, unless designated as confidential by a specific statute of the State of Nevada, will be treated as public records pursuant to NRS chapter 239 and shall be available for inspection and copying by any person, as defined in NRS 0.039, or any governmental entity. Contractor expressly and indefinitely waives all of its rights to bring, including but not limited to, by way complaint, interpleader, intervention, or any third party practice, any claims, demands, suits, actions, judgments, or executions, for damages or any other relief, in any administrative or judicial forum, against the County or any of its officers or employees, in either their official or individual capacity, for violations of or infringement of the copyright laws of the United States or of any other nation.

19. INDEMNIFICATION. To the fullest extent permitted by law, Contractor shall, at its sole cost and expense, defend, hold harmless and indemnify County and its elected officials, officers, attorneys, agents, employees, volunteers, successors, assigns and those County agents serving as independent consultants in the role of County officials (collectively "Indemnitees"), from and against any and all damages, costs, expenses, liabilities, claims, demands, causes of action, proceedings, expenses, judgments, penalties, liens, and losses of any nature whatsoever, including fees of accountants, attorneys, or other professionals and all costs associated therewith and the payment of all consequential damages (collectively "Liabilities"), in law or equity, whether actual, alleged or threatened, which arise out of, are claimed to arise out of, pertain to, or relate to the acts or omissions of Contractor, its officers, agents, servants, employees, subcontractors, materialmen, consultants or their officers, agents, servants, or employees (or any entity or individual that Contractor shall bear the legal liability thereof) in the performance of this Contract, including the Indemnitee's active or passive negligence, except for Liabilities arising from the sole negligence or willful misconduct of the Indemnitees as determined by court decision or by the agreement of the Parties. Contractor shall defend the Indemnitees in any action or actions filed in connection with any Liabilities with counsel of Indemnitees' choice, and shall pay all costs and expenses, including all attorneys' fees and experts' costs actually incurred in connection with such defense. Contractor shall reimburse the Indemnitees for any and all legal expenses and costs incurred by Indemnitees in connection therewith.

Contractor shall obtain executed indemnity agreements with provisions identical to those in this Contract from each and every subcontractor or any other person or entity involved by, for, with or on behalf of the Contractor in the performance of this Contract.

County does not, and shall not, waive any rights that it may possess against Contractor because of the acceptance by County, or the deposit with County, of any insurance policy or certificate required pursuant to this Contract. The Indemnitees in this Contract shall apply regardless of whether or not any insurance policies are determined to be applicable to the Liabilities, tax, assessment, penalty or interest asserted against County.

The provisions of this Section 19 shall survive the termination of this Contract. County may offset against the amount of any fees due to Contractor under this Contract any amount due to County from Contractor as a result of Contractor's failure to promptly pay County any reimbursement or indemnification arising under this Contract.

20. MODIFICATION OF CONTRACT. The Contract and the attachment constitute the entire agreement and understanding between the Parties and may only be modified by a written amendment signed by both of the Parties.

21. AUTHORITY. The Parties represent and warrant that they have the authority to enter into this Contract. Each signatory individually warrants that he or she is authorized to sign on behalf of the party for whom he or she is signing.

22. STANDARD OF CARE. Contractor will perform all services in a manner consistent with that level of care and skill ordinarily exercised by other members of Contractor's profession currently practicing in the same locality under similar conditions.

23. BOYCOTT OF ISRAEL. If the annual amount required to perform this Contract (identified in Paragraph 3 of this Contract) exceeds \$100,000, then by signing this Contract, Contractor certifies that it is not currently engaged in, and agrees for the duration of the contract not to engage in, a boycott of Israel as defined in NRS 332.065.

24. WAIVER OF LIEN. Contractor understands and agrees that the services it will render to the County are not intended for the improvement of real property or to otherwise grant any rights to Contractor pursuant to NRS chapter 108.

25. THIRD PARTY BENEFICIARY. Nothing contained in this Contract is intended to convey any rights or to create a contractual relationship with any third party or to otherwise allow a third party to assert a cause of action against either Contractor or County.

26. FORCE MAJEURE. Neither Party shall be deemed to be in violation of this Contract if it is prevented from performing any of its obligations hereunder due to protests, strikes, legal impossibility, failure of public transportation, civil or military authority, act of public enemy, accidents, fires, explosions, emergencies or acts of God, including, without limitation, earthquakes, floods, winds, or storms. In such an event, the intervening cause must not be through the fault of the Party asserting such an excuse, and the excused Party is obligated to promptly perform in accordance with the terms of this Contract after the intervening cause ceases.

27. WAIVER. The County's failure to insist upon Contractor's performance of any obligation hereunder shall not constitute a waiver of the County's right to enforce that obligation and the County may require compliance with that obligation or any other obligation at any time.

28. NOTICES. All notices, requests, demands and other communications hereunder must be in writing and will be deemed delivered when sent via certified mail, return receipt requested or by commercial courier, provided the courier's regular business is delivery service and provided further that it guarantees delivery to the addressee by the end of the next business day following the courier's receipt from the sender, addressed as follows (or any other address that the Party to be notified may have designated to the sender by like notice):

To County: Douglas County
Attn: Community Services Director
Post Office Box 218
Minden, Nevada 89423

To Contractor: Central Sierra Construction, Inc.
2551 Precision Drive, Suite C
Minden, NV 89423

29. CONFLICT OF INTEREST. By signing the Contract, Contractor agrees that any information obtained from Douglas County, in whatever form, will not be divulged to other competing interests without the permission of the County Manager. In the event of a breach of this provision, Douglas County may immediately withdraw, without penalty or any payment, from the Contract. Contractor must notify Douglas County of any other contracts or projects Contractor is working on that may impact Douglas County.

IN WITNESS WHEREOF, the Parties hereto have caused the Contract to be signed and intend to be legally bound thereby.

Central Sierra Construction, Inc.

By: William A. Park 6-6-24
Name: WILLIAM A. PARK
Title: PRESIDENT (Date)

Douglas County

By: Jenifer Davidson 06/20/2024
Jenifer Davidson, County Manager (Date)

Central Sierra Construction, Inc.

General Building Contractor
2551 Precision Dr., Ste. C, Minden, NV 89423
775-267-2943 / 775-267-3642 Fax
NV lic#23444B

Date: June 6, 2024

Proposal submitted to:
Douglas County
Attn: Scott McCullough

Job Name: DC Announcers Booth Restoration
Job Address: Douglas County Fairgrounds

We hereby propose to provide all labor, equipment and materials to perform restoration work as detailed in Plans from TSK, dated 4-1-2024. All materials provided by owner- lumber, drywall, paint, windows and roofing.

TOTAL BID: \$49,700.00

Exclusions: **Any and all work not detailed above. Engineering. No off hour wages. No permits, drawings and fees.**

Payment to be made as follows: **MONTHLY PROGRESS PAYMENTS AS WORK IS COMPLETED**

All material is guaranteed to be as specified. All work to be completed in a workmanlike manner according to standard practices. Any alteration or deviation from above specifications involving extra costs will be executed only upon written orders, and will become an extra charge over and above the estimate. All agreements are contingent upon strikes, accidents or delays beyond our control.

Authorized Signature William Park Date: 5-2-2024

Note: This proposal may be withdrawn by us if not accepted within 30 days.

Acceptance of Proposal - The above prices, specifications and conditions are satisfactory and are hereby accepted. You are authorized to do the work as specified. Payment will be made as outlined above.

Date of Acceptance: _____ Signature _____



Hangar Map

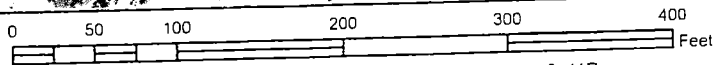

Print Date 10/9/2014 -- File Name Hangar_Map_8x11P

The data contained herein has been compiled on a geographic information system for the use of Douglas County. The data does not represent survey delineation and should not be considered as a replacement for the authoritative source, plat maps, deeds, resurveys etc. No liability is assumed by Douglas County or MAGIC as to the sufficiency or accuracy of the data.

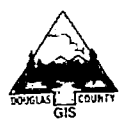

DC ANNOUNCERS BOOTH RESTORATION

BID ISSUE
04/01/2024

PROJECT ADDRESS:
920 PINENUT RD.
GARDNERVILLE, NEVADA 89410



VELOCITY MAP

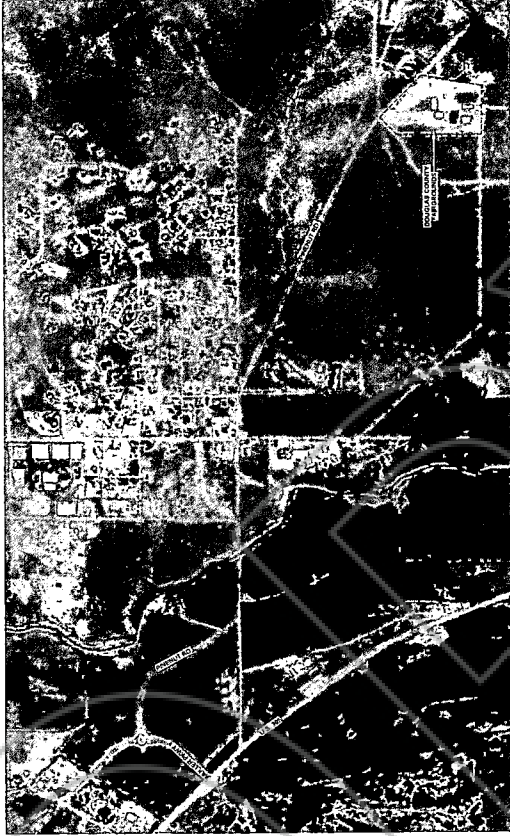

PROJECT SITE



CLIENT:
DOUGLAS COUNTY

BID ISSUE
04/01/2024

tsk

314 South Ward Street,
Salt Lake City, UT 84115
Phone: 702.456.3000
Fax: 702.456.3000
tsk.com



THESE DOCUMENTS ARE THE PROPERTY OF TSK ARCHITECTS. ANY REPRODUCTION OR DISTRIBUTION OF THESE DOCUMENTS WITHOUT THE WRITTEN PERMISSION OF TSK ARCHITECTS IS STRICTLY PROHIBITED. THIS DOCUMENT IS NOT TO BE USED FOR ANY OTHER PROJECT OR IN ANY OTHER MANNER WITHOUT THE WRITTEN PERMISSION OF TSK ARCHITECTS. Copyright, Ltd 2024

DESIGN TEAM
ARCHITECT
TSK ARCHITECTS
225 S. ARLINGTON AVE, SUITE A
RENO, NEVADA 89501

PLEASE RECYCLE
PRINT
DC ANNOUNCERS
BOOTH
RESTORATION
920 PINENUT RD.
GARDNERVILLE,
NEVADA 89410

Job No 24-006
Owner
DOUGLAS COUNTY



THIS DRAWING AND SPECIFICATIONS ARE PREPARED BY TSK ENGINEERS AND ARCHITECTS IN ACCORDANCE WITH THE PROFESSIONAL STANDARDS OF THE BOARD OF PROFESSIONAL ENGINEERS AND ARCHITECTS OF THE STATE OF NEVADA. ALL INFORMATION IS TO BE CHECKED BY THE CONTRACTOR. TSK ENGINEERS AND ARCHITECTS DOES NOT WARRANT ANY AND ACCEPTS NO LIABILITY FOR ANY DAMAGE OR LOSS OF ANY KIND, INCLUDING BUT NOT LIMITED TO, THE COST OF REPAIRS AND DAMAGES.

Copyright, 1972

PLEASE RECYCLE
**DC ANNOUNCERS
BOOTH
RESTORATION**
920 PINEHURST RD.
GARDNERVILLE,
NEVADA 89410

JOB No. 74-005
DOUGLAS COUNTY

BID ISSUE

DATE	REVISION	DESCRIPTION

SEE DRAWING FOR
**DEMOLITION PLANS,
ELEVATIONS AND
PHOTOS**

DATE: 04/20/2024
SHEET: 16

A1.01

GENERAL NOTES

1. DEMOLITION WORK SHALL BE ACCORDING TO THE REQUIREMENTS OF THE NEVADA BOARD OF PROFESSIONAL ENGINEERS AND ARCHITECTS.
2. ALL DEMOLITION WORK SHALL BE ACCORDING TO THE REQUIREMENTS OF THE NEVADA BOARD OF PROFESSIONAL ENGINEERS AND ARCHITECTS.
3. ALL DEMOLITION WORK SHALL BE ACCORDING TO THE REQUIREMENTS OF THE NEVADA BOARD OF PROFESSIONAL ENGINEERS AND ARCHITECTS.
4. ALL DEMOLITION WORK SHALL BE ACCORDING TO THE REQUIREMENTS OF THE NEVADA BOARD OF PROFESSIONAL ENGINEERS AND ARCHITECTS.
5. ALL DEMOLITION WORK SHALL BE ACCORDING TO THE REQUIREMENTS OF THE NEVADA BOARD OF PROFESSIONAL ENGINEERS AND ARCHITECTS.
6. ALL DEMOLITION WORK SHALL BE ACCORDING TO THE REQUIREMENTS OF THE NEVADA BOARD OF PROFESSIONAL ENGINEERS AND ARCHITECTS.
7. ALL DEMOLITION WORK SHALL BE ACCORDING TO THE REQUIREMENTS OF THE NEVADA BOARD OF PROFESSIONAL ENGINEERS AND ARCHITECTS.
8. ALL DEMOLITION WORK SHALL BE ACCORDING TO THE REQUIREMENTS OF THE NEVADA BOARD OF PROFESSIONAL ENGINEERS AND ARCHITECTS.
9. ALL DEMOLITION WORK SHALL BE ACCORDING TO THE REQUIREMENTS OF THE NEVADA BOARD OF PROFESSIONAL ENGINEERS AND ARCHITECTS.
10. ALL DEMOLITION WORK SHALL BE ACCORDING TO THE REQUIREMENTS OF THE NEVADA BOARD OF PROFESSIONAL ENGINEERS AND ARCHITECTS.
11. ALL DEMOLITION WORK SHALL BE ACCORDING TO THE REQUIREMENTS OF THE NEVADA BOARD OF PROFESSIONAL ENGINEERS AND ARCHITECTS.
12. ALL DEMOLITION WORK SHALL BE ACCORDING TO THE REQUIREMENTS OF THE NEVADA BOARD OF PROFESSIONAL ENGINEERS AND ARCHITECTS.
13. ALL DEMOLITION WORK SHALL BE ACCORDING TO THE REQUIREMENTS OF THE NEVADA BOARD OF PROFESSIONAL ENGINEERS AND ARCHITECTS.
14. ALL DEMOLITION WORK SHALL BE ACCORDING TO THE REQUIREMENTS OF THE NEVADA BOARD OF PROFESSIONAL ENGINEERS AND ARCHITECTS.
15. ALL DEMOLITION WORK SHALL BE ACCORDING TO THE REQUIREMENTS OF THE NEVADA BOARD OF PROFESSIONAL ENGINEERS AND ARCHITECTS.
16. ALL DEMOLITION WORK SHALL BE ACCORDING TO THE REQUIREMENTS OF THE NEVADA BOARD OF PROFESSIONAL ENGINEERS AND ARCHITECTS.
17. ALL DEMOLITION WORK SHALL BE ACCORDING TO THE REQUIREMENTS OF THE NEVADA BOARD OF PROFESSIONAL ENGINEERS AND ARCHITECTS.
18. ALL DEMOLITION WORK SHALL BE ACCORDING TO THE REQUIREMENTS OF THE NEVADA BOARD OF PROFESSIONAL ENGINEERS AND ARCHITECTS.
19. ALL DEMOLITION WORK SHALL BE ACCORDING TO THE REQUIREMENTS OF THE NEVADA BOARD OF PROFESSIONAL ENGINEERS AND ARCHITECTS.
20. ALL DEMOLITION WORK SHALL BE ACCORDING TO THE REQUIREMENTS OF THE NEVADA BOARD OF PROFESSIONAL ENGINEERS AND ARCHITECTS.

REVNOTES

1. REVISED DRAWING TO SHOW...
2. REVISED DRAWING TO SHOW...
3. REVISED DRAWING TO SHOW...
4. REVISED DRAWING TO SHOW...
5. REVISED DRAWING TO SHOW...
6. REVISED DRAWING TO SHOW...
7. REVISED DRAWING TO SHOW...
8. REVISED DRAWING TO SHOW...
9. REVISED DRAWING TO SHOW...
10. REVISED DRAWING TO SHOW...
11. REVISED DRAWING TO SHOW...
12. REVISED DRAWING TO SHOW...
13. REVISED DRAWING TO SHOW...
14. REVISED DRAWING TO SHOW...
15. REVISED DRAWING TO SHOW...
16. REVISED DRAWING TO SHOW...
17. REVISED DRAWING TO SHOW...
18. REVISED DRAWING TO SHOW...
19. REVISED DRAWING TO SHOW...
20. REVISED DRAWING TO SHOW...

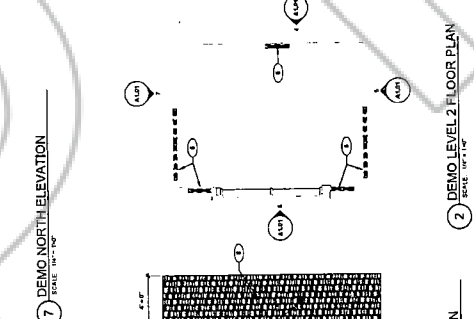
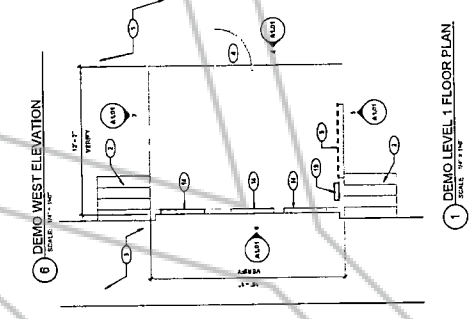
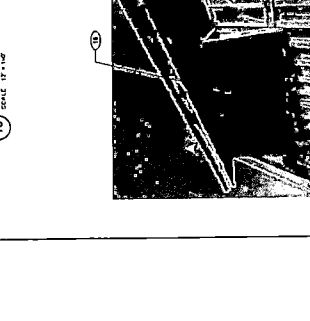
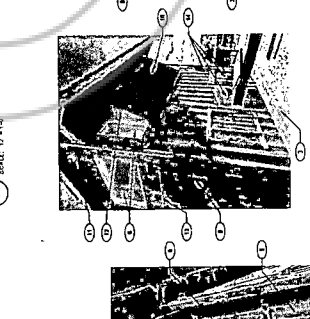
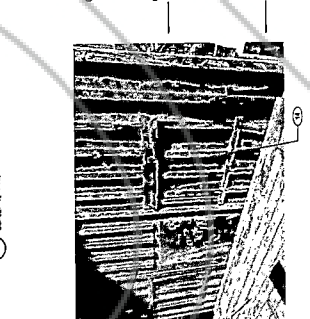
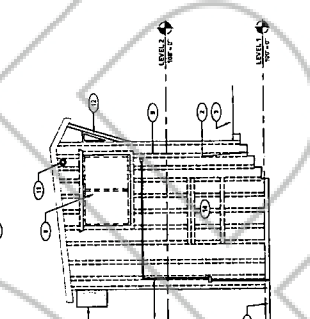
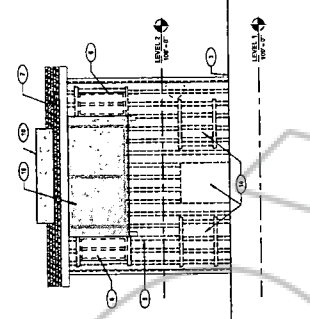
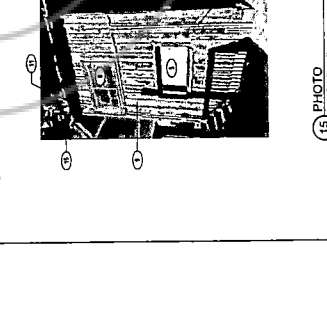
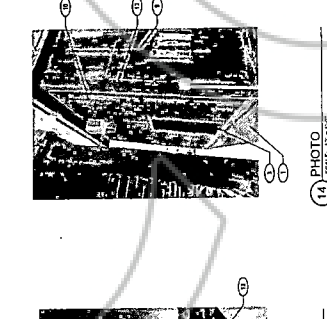
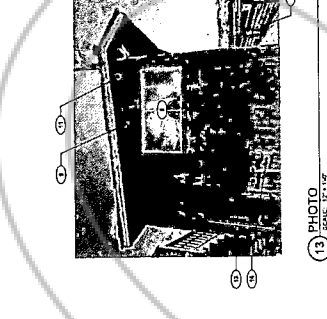
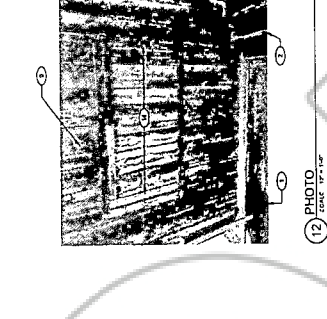
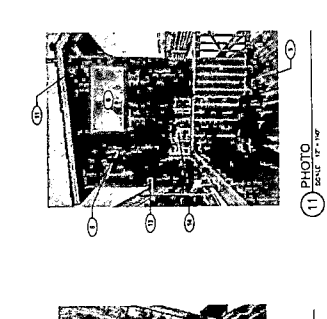
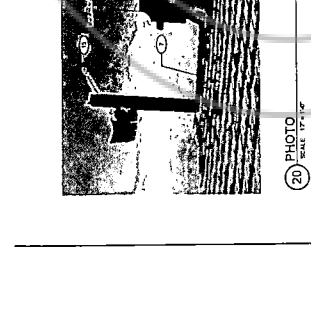
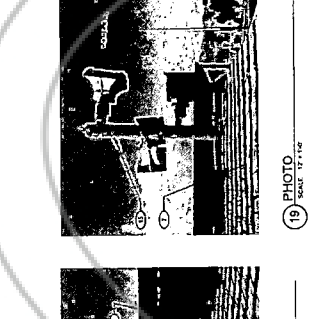
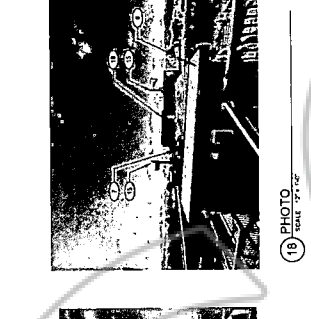
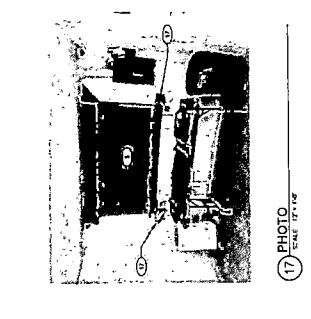
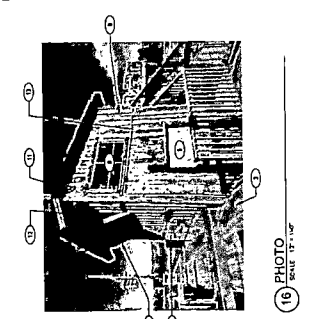

1 DEMO LEVEL 1 FLOOR PLAN
2 DEMO LEVEL 2 FLOOR PLAN
3 DEMO ROOF PLAN
4 DEMO EAST ELEVATION
5 DEMO SOUTH ELEVATION
6 DEMO WEST ELEVATION
7 DEMO NORTH ELEVATION



THIS DOCUMENT IS THE PROPERTY OF TSK INC. AND IS TO BE USED ONLY FOR THE PROJECT AND SITE SPECIFICALLY IDENTIFIED ON THE DRAWINGS. IT IS NOT TO BE REPRODUCED, COPIED, OR TRANSMITTED IN ANY FORM OR BY ANY MEANS, ELECTRONIC OR MECHANICAL, INCLUDING PHOTOCOPYING, RECORDING, OR BY ANY INFORMATION STORAGE AND RETRIEVAL SYSTEM, WITHOUT THE WRITTEN PERMISSION OF TSK INC. ANY UNAUTHORIZED USE OF THIS DOCUMENT IS STRICTLY PROHIBITED.

Copyright, Ltd 2024
Comment:
1. ALL WORK SHALL BE IN ACCORDANCE WITH THE 2024 IBC AND ALL APPLICABLE CODES.
2. ALL MATERIALS SHALL BE NEW UNLESS OTHERWISE NOTED.
3. ALL WORK SHALL BE DONE IN ACCORDANCE WITH THE 2024 IBC AND ALL APPLICABLE CODES.
4. ALL WORK SHALL BE DONE IN ACCORDANCE WITH THE 2024 IBC AND ALL APPLICABLE CODES.
5. ALL WORK SHALL BE DONE IN ACCORDANCE WITH THE 2024 IBC AND ALL APPLICABLE CODES.
6. ALL WORK SHALL BE DONE IN ACCORDANCE WITH THE 2024 IBC AND ALL APPLICABLE CODES.
7. ALL WORK SHALL BE DONE IN ACCORDANCE WITH THE 2024 IBC AND ALL APPLICABLE CODES.
8. ALL WORK SHALL BE DONE IN ACCORDANCE WITH THE 2024 IBC AND ALL APPLICABLE CODES.
9. ALL WORK SHALL BE DONE IN ACCORDANCE WITH THE 2024 IBC AND ALL APPLICABLE CODES.
10. ALL WORK SHALL BE DONE IN ACCORDANCE WITH THE 2024 IBC AND ALL APPLICABLE CODES.
11. ALL WORK SHALL BE DONE IN ACCORDANCE WITH THE 2024 IBC AND ALL APPLICABLE CODES.
12. ALL WORK SHALL BE DONE IN ACCORDANCE WITH THE 2024 IBC AND ALL APPLICABLE CODES.

PLEASE RECYCLE
PROJECT
**DC ANNOUNCERS
BOOTH
RESTORATION**
930 FINEMUT RD,
GARDENVILLE,
NEVADA 89410

Job No: 24-000
Owner:
DOUGLAS COUNTY

BID ISSUE

REV	DATE	DESCRIPTION

Sheet Title:
**PROPOSED PLANS,
ELEVATIONS AND
DETAILS**

Scale: AS SHOWN
Date: 10/24/24

- GENERAL NOTES**
1. ALL WORK SHALL BE IN ACCORDANCE WITH THE 2024 IBC AND ALL APPLICABLE CODES.
 2. ALL MATERIALS SHALL BE NEW UNLESS OTHERWISE NOTED.
 3. ALL WORK SHALL BE DONE IN ACCORDANCE WITH THE 2024 IBC AND ALL APPLICABLE CODES.
 4. ALL WORK SHALL BE DONE IN ACCORDANCE WITH THE 2024 IBC AND ALL APPLICABLE CODES.
 5. ALL WORK SHALL BE DONE IN ACCORDANCE WITH THE 2024 IBC AND ALL APPLICABLE CODES.
 6. ALL WORK SHALL BE DONE IN ACCORDANCE WITH THE 2024 IBC AND ALL APPLICABLE CODES.
 7. ALL WORK SHALL BE DONE IN ACCORDANCE WITH THE 2024 IBC AND ALL APPLICABLE CODES.
 8. ALL WORK SHALL BE DONE IN ACCORDANCE WITH THE 2024 IBC AND ALL APPLICABLE CODES.
 9. ALL WORK SHALL BE DONE IN ACCORDANCE WITH THE 2024 IBC AND ALL APPLICABLE CODES.
 10. ALL WORK SHALL BE DONE IN ACCORDANCE WITH THE 2024 IBC AND ALL APPLICABLE CODES.
 11. ALL WORK SHALL BE DONE IN ACCORDANCE WITH THE 2024 IBC AND ALL APPLICABLE CODES.
 12. ALL WORK SHALL BE DONE IN ACCORDANCE WITH THE 2024 IBC AND ALL APPLICABLE CODES.

- REVISIONS**
1. CORRECTED PER COMMENTS.
 2. REVISED MATERIALS LIST.
 3. REVISED FINISHES.
 4. REVISED WINDOW TYPES.
 5. REVISED DOOR TYPES.
 6. REVISED TRIM TYPES.
 7. REVISED FLOOR FINISHES.
 8. REVISED WALL FINISHES.
 9. REVISED CEILING FINISHES.
 10. REVISED LIGHTING FIXTURES.
 11. REVISED MECHANICAL EQUIPMENT.
 12. REVISED ELECTRICAL SYMBOLS.

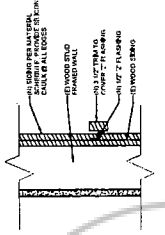
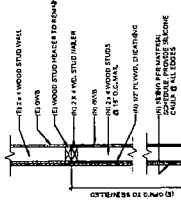

8 - EXISTING OPENING INFILL DETAIL
SCALE: 1/4" = 1'-0"

12 - HORIZ. TRIM DETAIL
SCALE: 3/4" = 1'-0"

NO.	DESCRIPTION	MODEL NUMBER	COLOR/FINISH	REMARKS
1	WOOD STUDS TO FRAME	12x16 WOOD STUD	STAINLESS STEEL	SEE WINDOW & DOOR ELEVATIONS FOR WINDOW TYPES.
2	WOOD STUDS TO FRAME	12x16 WOOD STUD	STAINLESS STEEL	SEE WINDOW & DOOR ELEVATIONS FOR WINDOW TYPES.
3	WOOD STUDS TO FRAME	12x16 WOOD STUD	STAINLESS STEEL	SEE WINDOW & DOOR ELEVATIONS FOR WINDOW TYPES.
4	WOOD STUDS TO FRAME	12x16 WOOD STUD	STAINLESS STEEL	SEE WINDOW & DOOR ELEVATIONS FOR WINDOW TYPES.
5	WOOD STUDS TO FRAME	12x16 WOOD STUD	STAINLESS STEEL	SEE WINDOW & DOOR ELEVATIONS FOR WINDOW TYPES.
6	WOOD STUDS TO FRAME	12x16 WOOD STUD	STAINLESS STEEL	SEE WINDOW & DOOR ELEVATIONS FOR WINDOW TYPES.
7	WOOD STUDS TO FRAME	12x16 WOOD STUD	STAINLESS STEEL	SEE WINDOW & DOOR ELEVATIONS FOR WINDOW TYPES.
8	WOOD STUDS TO FRAME	12x16 WOOD STUD	STAINLESS STEEL	SEE WINDOW & DOOR ELEVATIONS FOR WINDOW TYPES.
9	WOOD STUDS TO FRAME	12x16 WOOD STUD	STAINLESS STEEL	SEE WINDOW & DOOR ELEVATIONS FOR WINDOW TYPES.
10	WOOD STUDS TO FRAME	12x16 WOOD STUD	STAINLESS STEEL	SEE WINDOW & DOOR ELEVATIONS FOR WINDOW TYPES.
11	WOOD STUDS TO FRAME	12x16 WOOD STUD	STAINLESS STEEL	SEE WINDOW & DOOR ELEVATIONS FOR WINDOW TYPES.
12	WOOD STUDS TO FRAME	12x16 WOOD STUD	STAINLESS STEEL	SEE WINDOW & DOOR ELEVATIONS FOR WINDOW TYPES.

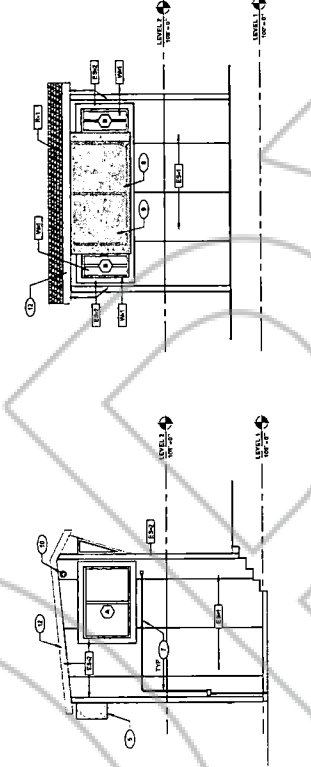

6 - WEST ELEVATION
SCALE: 1/4" = 1'-0"

7 - NORTH ELEVATION
SCALE: 1/4" = 1'-0"

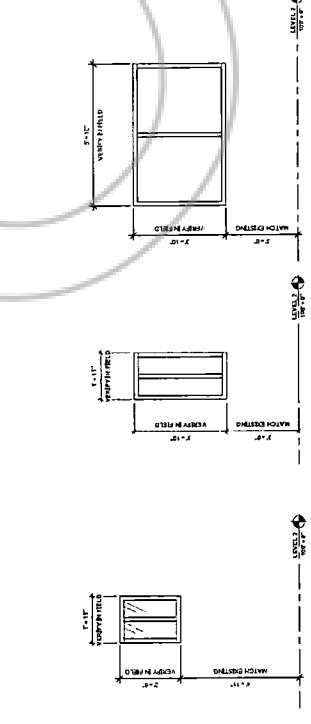

5 - SOUTH ELEVATION
SCALE: 1/4" = 1'-0"

WINDOW TYPES

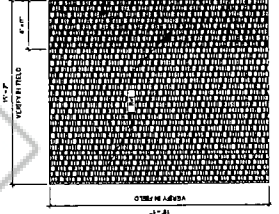

3 - ROOF PLAN
SCALE: 1/4" = 1'-0"

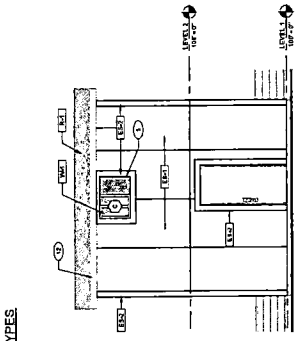

4 - EAST ELEVATION
SCALE: 1/4" = 1'-0"

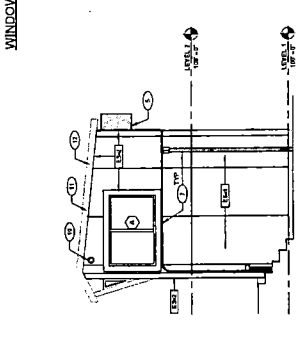

1 - LEVEL 1 FLOOR PLAN
SCALE: 1/4" = 1'-0"



2 - LEVEL 2 FLOOR PLAN
SCALE: 1/4" = 1'-0"

COPY

Douglas County, State of Nevada

CERTIFIED COPY

I certify that the document to which this certificate is attached is a full and correct copy of the original record on file in the Clerk-Treasurer's Office on this

21st day of June, 2024

By Chanya Balala Deputy